

RAINBOW MICRO HYDRO

Instruction Manual

Issue # 4 August 2001



Certified by: OFFICE OF ENERGY (NSW)
Certificate of Suitability Number: 6273



Rainbow Micro Hydro Instruction Manual

Foreword		page 2
Chapter 1 Safety		page 2
	Electrical Safety	page 2
	Turbine Safety	page 2
Chapter 2 Description	Pipe Suction	page 2
	Specifications	page 3
	Optimum Power	page 3
	Battery Based System	page 3
	Multiple Power Sources	page 3
	Regulation	page 3
	Maintenance	page 3
	Hardware	page 3
	Generator	page 3
	Control Box	page 3
	Dependent on Water Supply	page 4
	Components - Water Supply	page 4
Chapter 3 Installation		page 5
Chapter 4 Installing Water Supply	Water Source	page 6
	Filter	page 6
	Filter Design	page 6
	Filter Blockage	page 6
	Filter Collapse	page 6
	Pipe Siting	page 8
	Syphons	page 8
	Floods	page 9
	Weeds	page 9
	Gate Valves	page 9
	Water Hammer	page 9
Chapter 5 Electrical Wiring	Outlet Drain Plumbing	page 9
	AC Transmission	page 10
	Siting Considerations	page 10
	Lightning Damage	page 10
	Hydro to Control Box	page 10
	Short Circuit Protection	page 10
	Load Dump	page 11
	DC to Battery	page 11
	Setting of Regulator	page 11
	Regulator Interaction	page 11
	Switching Regulators	page 11
	Shunt Regulators	page 11
Chapter 6 Adjustment	Hybrid Power (Solar, Wind & Hydro)	page 13
	Nozzles	page 15
	Power Limit	page 15
	Control Knobs	page 15
	Turbine Speed	page 15
	Generator Voltage	page 15
	Visual Adjustment	page 15
	Regulator	page 16
	Output Power	page 16
	Meters	page 16
	Indicator Lights	page 16
Chapter 7 Periodic Maintenance	Fuse	page 16
	Load Dump	page 18
	Runner	page 18
	Generator	page 18
	Bearings	page 18
	Type of Grease	page 18
	Reassembly	page 18
	Plumbing	page 19
	Changing Nozzles	page 19
Chapter 8 Trouble Shooting		page 19
Appendix A Site Considerations	Head	page 21
	Flow	page 21
	Selection of Pipe Size	page 21
	Estimating Power Output	page 21
	Suggested Pipe Sizes	page 22
Appendix B Micro Hydro Performance		page 23
Appendix C Head Loss		page 24
Appendix D Pressure Conversion		page 25
Appendix E Nozzle Combinations		page 26
Appendix F Cable Sizing		page 27
Appendix G Technical Information		page 28
Appendix H Environmental Impact		page 31

Foreword

Congratulations! You have just bought our state-of-the-art micro hydro generator. This is a standard Australian made product adaptable to a range of sites and not a one-off unit custom made for your site. As a result, parts are interchangeable and repairs easy. It has been specially designed to work in a great variety of sites at a respectable efficiency. The Micro Hydro Power Unit is made from recyclable Low Density Polyethylene. The best form of recycling however is to continue using this moulding for its intended purpose. Please contact Rainbow Power Company for advise on servicing and replacing components.

Please take note of safety issues as discussed below. Chapter 3 provides a point by point summarised installation guide. If you need more information on installation you can refer to the subsequent Chapters.

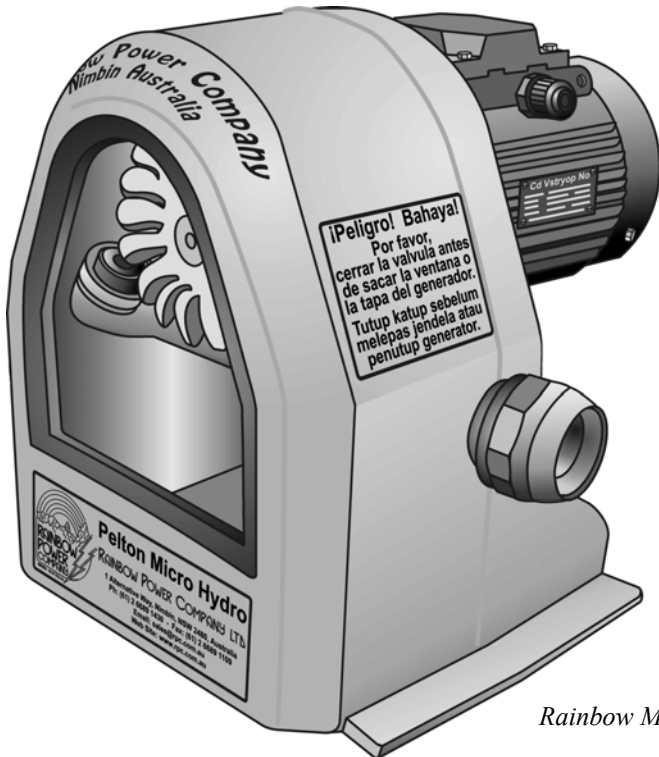

Rainbow Micro Hydro Power Unit

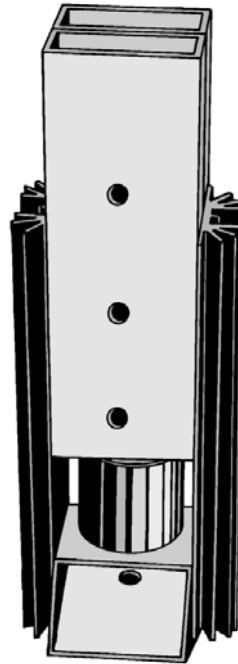

Load Dump

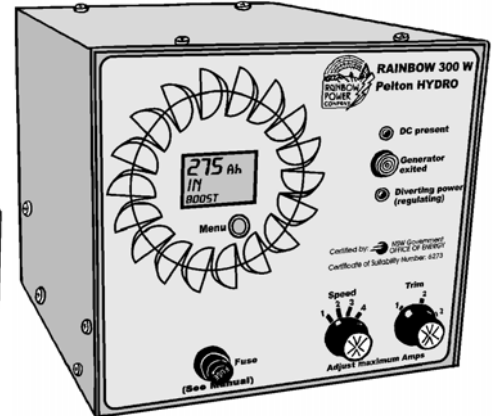

Rainbow Micro Hydro Control Unit

Rainbow Micro Hydro Chapter 1 Safety

Some aspects of this turbine/generator present safety hazards unless careful attention is paid to proper installation.

Electrical Safety

The power from the generator is at voltages comparable to conventional mains power. Contact with a live conductor may be lethal. Particular care should be given to the insulation and protection of the transmission cable. This cable must be installed under the supervision of a licensed electrician, to Australian Standard AS3000 and to the specifications as set out in Chapter 5 (Battery and Electrical). Never perform any work on the transmission cable without turning the water supply to the Micro Hydro off (Refer Chapter 5).

Turbine Safety

An important safety issue concerns the turbine. Children love poking sticks into things which spin around. Bits of the wheel could break off and get in their eyes at high velocity. Loose clothing could also be wound in by the rotating wheel causing injuries to fingers. If the turbine site is likely to be frequented by children then the unit must be kept in a locked shed.

Pipe Suction

The provision of an intake filter at the water source, while being important to prevent turbine damage and pipe blockage, is also required to stop small animals and children's hands from being sucked into the pipe (Refer Chapter 4).

Chapter 2

Rainbow Micro Hydro Description

Specifications

Turbine Impeller Type:	132mm diam. pelton wheel	Cooling:	(TEFC) Shaft mounted fan
Impeller Material:	Cast Epoxy Resin Composite	Generator Voltage:	#370VAC
Flow Control:	Changeable Nozzles	Maximum Power:	300W
Maximum Nozzle:	2 × 18.1mm	Speed Control*:	Adjustable capacitors
Minimum Nozzle:	1 × 1.6mm	Charger/Control box Type:	High frequency switch mode variable ratio
Maximum Head:	150m	Regulated Output Voltage Range:	(See Plasmatronics Manual)
Minimum Useable Head:	7m	Input-Output Electrical Isolation:	>2500V
Maximum Flow:	7 litres/second	Regulation:	Adjustable Shunt
Minimum Flow:	0.2 litres/second	Regulator Load:	Air Cooled Element
Generator Type:	Capacitively excited 3 phase 4 pole induction converter		

* This feature avoids the need for site customised specially wound generators which are often used on small hydro systems.

Optimum Power Available for Minimal Flow

The main advantage with the hydro having a battery based system is that you do not need to match the hydro to the current draw of the loads. The hydro output can be significantly lower than the peak power consumption of the loads with the battery acting as storage and capable of handling surges. In this manner, the Micro Hydro can be charging the battery when the loads are off, thereby making good use of the continuing water flow. A hydro to power loads directly would need to be a much larger unit to cope with peak loads and hence would require a much greater water volume.

Battery Based System

With the energy stored in the battery carrying short duration heavy loads such as power tools, washing machines, vacuum cleaners and irons. The turbine can appear to be 10 times the size as one with no storage. This is the reason our unit uses so little water compared to more conventional 240 volt micro-hydro generation systems which have no battery storage.

Multiple Power Sources

Another advantage of having a battery centred system is that it facilitates the incorporation of other charging systems into the one network. Solar panels, gen-set, wind generators, or other power sources can be simply connected into the same battery bank and will all power your system whatever the weather.

Regulation of Other Power Sources

Note that the voltage regulator in the hydro unit will only control hydro power and cannot dump surplus power from other sources. Their regulation must be independently controlled by using a general purpose shunt regulator with diode or switching regulator to take care of solar panels.

Maintenance

The only wearing parts are the nozzles and the runner which are easily replaced and the two standard ball races which are very lightly stressed. There are no brushes to wear out and the machine is able to run for years without overhaul. A hydro used periodically would require less maintenance.

Hardware

The moulded Low Density Polyethylene chassis makes this Micro Hydro unit very durable and quiet (vibration is imperceptible). The wheel itself is brittle, but wear resistant. The light weight of the resin pelton wheel is actually an advantage as bearing loads and imbalance are reduced. Flywheel effect has no advantage with a constant power input as is the case with the micro hydro.

Generator

The generator is a three-phase 415 volt induction motor which works even better as a generator. After ten years experimenting with many types of generator, we have decided that this is the best for versatility, robustness, efficiency, cost, availability and lifespan.

Control Box

The control box serves the multiple purpose of exciting the generator, reducing the voltage to 12 or 24, shedding excess power not wanted by the battery, and acting as a control box with ampmeter, voltmeter, fuse, indicator lights and connectors for the output wires. Excess power is redirected to the dump load which is an electric water heating element surrounded by aluminium air heating fins. If you are concerned about water or power wastage, some other load diversion could be arranged, or a 12 or 24 volt water solenoid could be incorporated into the system and controlled by the built-in regulator. Contact Rainbow Power Company about these options.

Components of the Water Supply

Hydro electric generators have specific requirements for the method of water delivery to ensure a cost effective working head and a consistent, reliable water supply free of gravel and debris. The standard components of the water supply include intake, headrace, forebay, penstock and tailrace although for many micro-hydro applications the intake and forebay are one and the same without a headrace separating them.

The intake is the structure which diverts water from the stream in order to supply water for the hydro. The intake should be designed so that enough water can pass through to keep the pipeline full and to prevent air from being drawn into the pipeline. A trashrack to keep out floating debris and stones is often included. Usually this consists of vertical steel bars across the intake channel. In order to minimise the intake of bed-load, the intake should be placed as nearly perpendicular to the direction of stream flow as possible and it should avoid any location where a natural sediment deposition tendency exists. The bottom of the intake channel should be raised above the bed of the stream to prevent the heavier bed-load material from being washed directly into the intake. Normal and flood water levels need to be taken into account. The headrace is a pipeline or canal that conveys the water from the intake to the forebay.

The forebay is a final settling area, with trashrack, just before the water enters the penstock. The depth of the forebay must be sufficient to prevent the formation of a vortex at the penstock entrance. A filter should be installed with a large surface area and sufficiently fine to prevent the intake of particles too large to pass through the nozzle of the hydro. A good trashrack may prevent stones and floating debris from clogging up the filter.

The penstock is the pipe used to convey water from the forebay to the turbine. This pipeline is of great importance to the performance of a micro-hydro power plant. The size of the penstock and its ability to withstand the pressure of the water must be carefully selected in order to optimise the performance of the hydro and to prevent problems during operation.

The tailrace is after the turbine where the water is usually returned to the stream downstream of the headrace.

Performance Dependent on Water Supply

The performance of any hydro-electric system is of course no better than its supply of water, so read on!

Note: The graph shown here gives the output in amps of a 12V Rainbow Micro Hydro induction turbine. Refer to pages 17 and 23 for more Hydro Performance graphs.

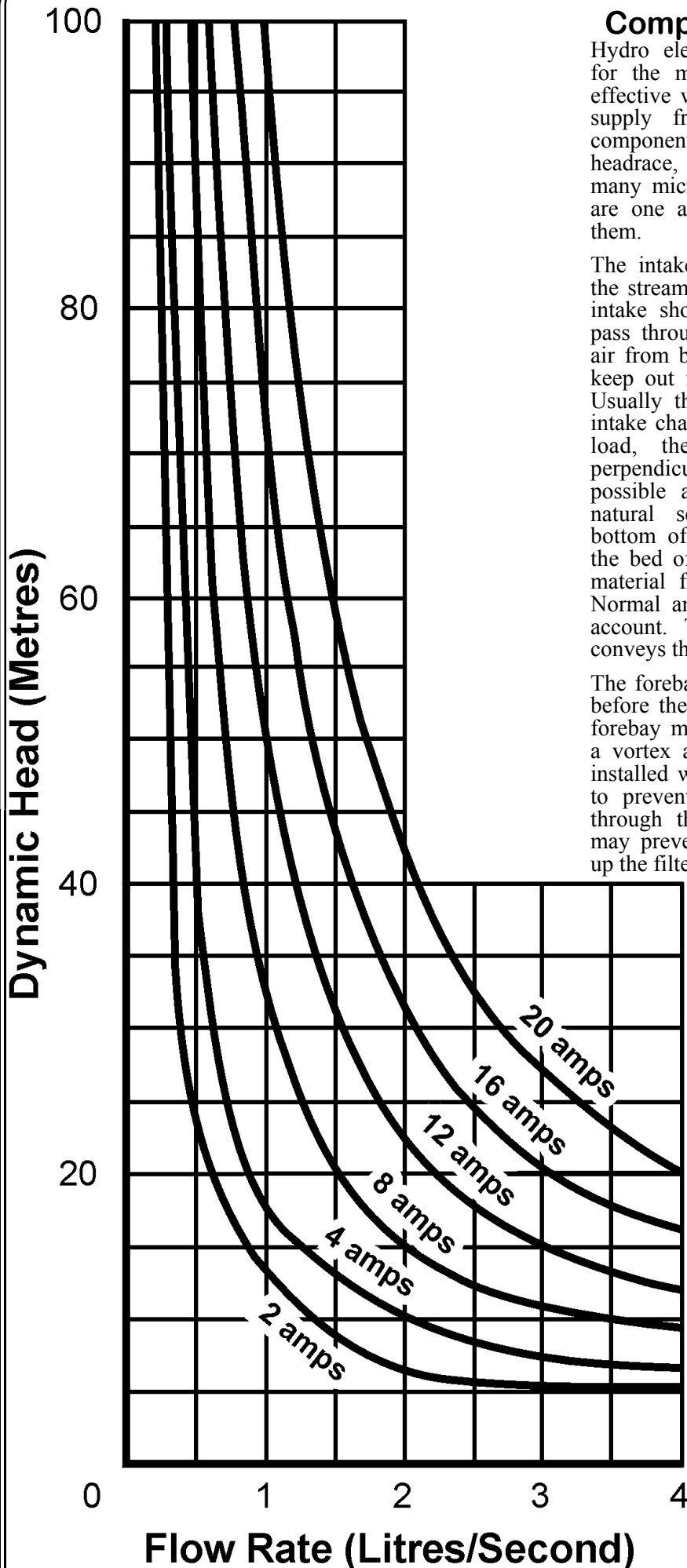

Chapter 3

Installation

- 1 Select a suitable site for the turbine. It should be located to provide the most pressure and optimum flow for the most cost effective combination of pipe and transmission cable.
- 2 Ensure the site is not subject to flooding.
- 3 Facilitate access for both water and electrical wiring.
- 4 Clear the area of weeds and obstructions.
- 5 The hydro needs to be kept in a shed or enclosure to provide extra protection against the environment and reduce noise. It is also advisable to have it bolted down onto a floor or fixed structure.
- 6 Provide a tail water drain to prevent flooding and erosion damage.
- 7 Install the water pipes, connectors, gate valve etc.
WARNING - A poorly designed penstock may cause pressure surges resulting in damage to the turbine or pipe.
Full detailed instructions on the proper installation of a penstock are given in Chapter 4. We urge you to study this information before purchasing or laying the pipe. Pay particular attention to the selection of pipe sizes and methods of avoiding airlocks.
- 8 Fit an intake filter.
WARNING: Failure to use an intake filter may result in damage to the turbine or pipe.
- 9 Assemble the supplied gate valve, pressure gauge and Camlock fitting as shown in the diagram on this page.
- 10 Using suitable bushings or adaptors (not supplied) to fit this assembly to the end of the penstock. The Rainbow Micro Hydro comes equipped with a 2" BSP fitting.
- 11 Fill the penstock with water, ensuring all air has been expelled. Follow the procedure as set out in Chapter 4.
- 12 Fit the camlock to the pelton housing.
- 13 Install the control box close to the battery to minimise battery cable loss. Refer to Appendix F for cable sizing data.
- 14 Ensure ample ventilation for the battery, control box and particularly the load dump resistor. Place all electrical fittings clear of corrosive fumes emitted from the battery. Refer to Australian Standards AS 2676.1, AS 3000, AS 3011.1 and AS 4509 for additional information.
- 15 Ensure the battery is suitable for the supplied unit (12 or 24 volt).
- 16 Connect suitable cables between control box and battery (see Chapter 5).
- 17 Connect the power transmission cable to the generator and fit the supplied plug at the control box end. This work must be performed by a qualified electrician. Closely follow the detailed instructions and advice given in Chapter 5.
- 18 Proceed with operation and adjustment of the machine as described in Chapter 6.

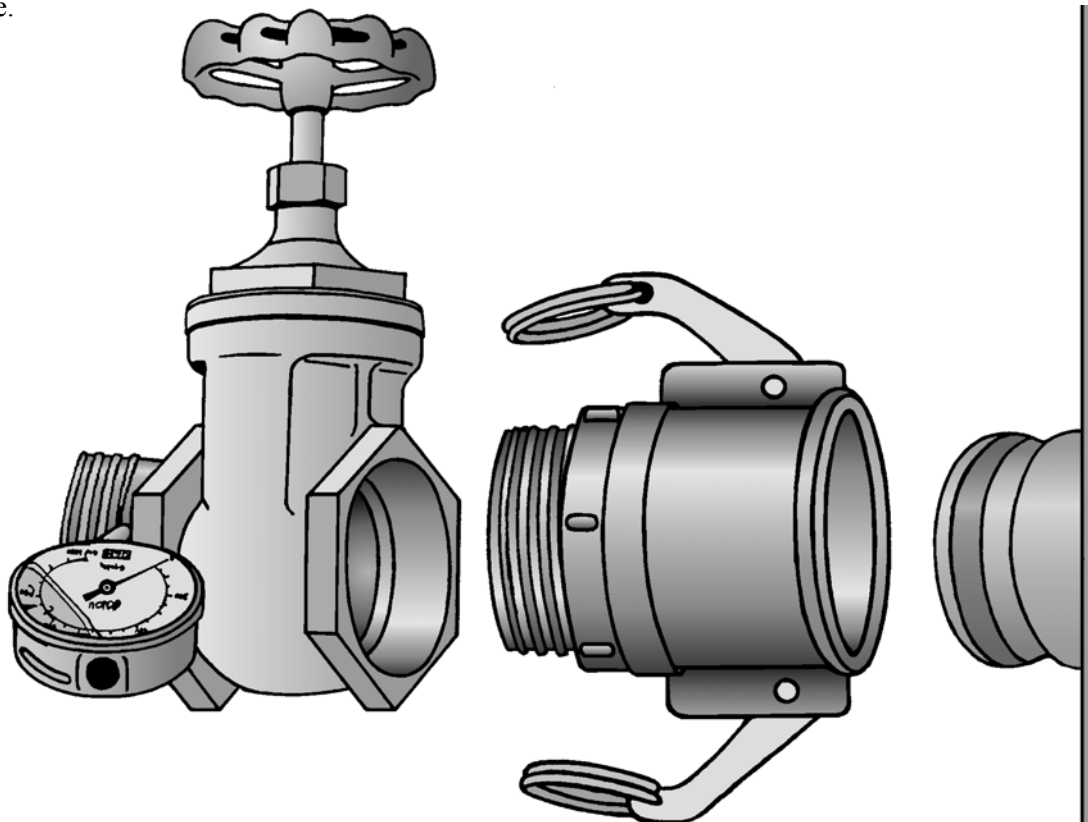

Chapter 4

Installing the Water Supply

Cross Section of Dam and Intake Pipe with Filter

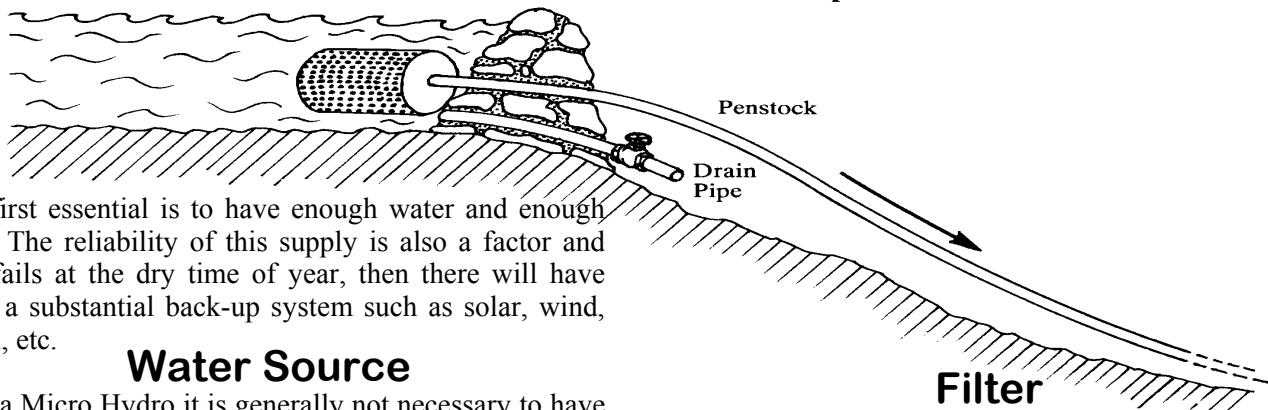

The first essential is to have enough water and enough head. The reliability of this supply is also a factor and if it fails at the dry time of year, then there will have to be a substantial back-up system such as solar, wind, diesel, etc.

Water Source

With a Micro Hydro it is generally not necessary to have a channel leading from a weir or dam to a forebay with a trash rack as you find in larger hydro setups. If you have very large amounts of debris at your water source, a trash rack before the filter may solve the problem. In most cases it is quite sufficient to have a small weir with an adequately sized filter inside the weir connected to the penstock, which is just a fancy name for the waterpipe that leads down to the hydro. Ideally there will be a small dam at the source of the water.

The dam serves several useful purposes:

1. It stores enough water to fill the pipe in one go without sucking air.
2. It stores enough water to flush the pipe of air and silt.
3. It secures the pipe well in floods.
4. It allows time for sand to settle and air bubbles to rise before being sucked into the pipe.
5. If installed as per diagram above, it is self priming and eliminates the need for a syphon.

Often only the cement powder needs to be carried to the source as sand and rocks are usually present in the stream bed. Preferably the wall of the dam is on bedrock for adhesion. The rock must be roughened with a hammer or pick before attaching the cement, otherwise the thin layer of moss and algae present on stream rock will prevent the cement sticking. The water can be kept away from the wet cement with a big syphon pipe, or by setting in a short length of pipe through the wall at the lowest place and later capping it or turning it off. This is obviously easier to do when the creek is low, but still surprisingly possible when there is lots of water. Plastic bags full of mortar are useful for poking in between rocks in fast-flowing sections. Mortar made dryish with 1:1 mixture can be made to stay in place under water and will set well without cracking because it is continuously wet. Allowing the mortar to 'gel' for half an hour will improve its resistance to washing away when applied under water. Alternatively the water can be diverted with hessian sacks or plastic bags filled with dirt.

There **MUST** be a filter at the inlet of the pipe. The most common cause of power failure in micro-hydro-electric systems is a clogged water intake! Gravel passing down the pipe will block and damage the nozzles. Getting rotten eels out of the pipe-work is difficult and very unpleasant! Platypus and turtles have been drowned by being sucked onto the ends of filterless pipes. Children's hands can also get stuck in pipes. If holes in the filter are too small they block too quickly. If holes are too large, particles will block the nozzle(s). If the area of the filter is too small, filter blockage will be a problem. The sum of all the holes must have an area at least ten times that of the end of the pipe. A coarse screen before a finer one is a good idea as leaves are caught by the first screen and don't stick over the fine mesh. In a big filter leaves will rot faster than they collect. Many people have theories about the stream washing rubbish off the filter. There is little evidence that filters are cleaned in this way.

Sometimes the bottom, or the top, of the filter will work better, subject to a variety of factors. Keep the filter midway between the bottom and the surface so that mud, silt and sand are not sucked up or too much floating debris is sucked onto the filter. A cover over the top of the filter can prevent a vortex from forming and sucking in air and floating debris.

The filter must also be **STRONG** so as to resist floods which roll rocks down stream beds. Location of the filter to one side of the stream can keep it out of the main force of the flooded stream. There are a number of commercially available filters suitable for the purpose. Contact Rainbow Power Company or your local pumping and filtration specialist for help.

The design of the filter is a critical issue. A Poorly designed filter can have repercussions and ongoing hassles in attempting to keep the hydro functioning. Don't use galvanised wire or bolts on a filter. They last a remarkably short time in aerated acid water. Stainless steel, brass, copper and plastic are the materials to use.

Filter Design

In designing an appropriate filter the following issues need to be considered:

- Size and depth of water pool.
- The size, amount and type of debris in the water, particularly during flooding and abnormal stream flow. Is the nature of the debris mainly floating or sinking (flotsam or jetsam) or is it a mixture.
- The suction head determined by the static head down to the micro hydro. The head and the flow rate combined can cause an inappropriately designed filter to collapse under the immense suction. You need to not only consider the suction determined by the maximum nozzle size that you would expect to use on the hydro, but the maximum flow rate that the pipe is capable of when you may need to open up the pipe in order to flush it of air pockets and debris or when there is an accidental breakage in the pipe. This flow rate can be far greater than the maximum flow of the stream which would then drain the reservoir of water in the pool if allowed to continue. The maximum flow rate of an open bore pipe can be calculated, given the maximum head, pipe length and pipe size. Rather than trying to work this out yourself – contact Rainbow Power Company and we can provide this value given the pipe length, pipe diameter and head.

The filter needs to be made out of material which doesn't corrode as the environment in which it is to be situated can be very corrosive. You also need to be aware that some plastics decay and become brittle as a result of prolonged UV exposure. Brass, stainless steel and polyethylene are suitable materials.

Quite a strong filter can be constructed out of expanded mesh. Heavily galvanised expanded mesh can last for many years in a fresh water environment and sewn into a cylindrical shape with stainless steel wire with two circles of expanded mesh sewn into both ends works quite well. Before it is sewn in, a hole should be made that is large enough for the pipe to go through and a pipe flange bolted to the mesh over the hole. A hole through the flange that lines up with a hole through the pipe can then be used to drop a long stainless steel bolt through to secure the filter on the end of the pipe. The large holes in the expanded mesh can be covered with a bag made out of shadecloth with a drawstring sewn into the opening to allow you to close it around the pipe. The largest holes in the filter need to be smaller than the smallest nozzle that you would expect to use on the hydro. As a minimum size filter of this type of construction we would suggest the size of a 10 litre drum.

Filter Blockage

If the turbine does not perform adequately, the temporary removal of the filter will soon show if this is limiting the flow to the hydro. If this makes a difference then the total area of holes in the filter is not large enough. Don't be tempted to run the hydro for very long without a filter as particles large enough to block the nozzle could get sucked in and cause a water hammer effect once it lodges in the nozzle. See page 9 for more information about water hammer.

If your creek has lots of leaf litter or a similar type of debris, then a larger filter will be less likely to be seriously blocked by such debris. Depending on the flow rate in the pipe, the filter will need to be sufficiently far below the pool surface to prevent a swirling eddy or vortex effect to suck debris onto the surface of the filter and to suck air into the pipe. Pockets of air in the pipe can cause much more severe water hammer than particles blocking the nozzle. Pockets of air can settle in any humps in the pipe. A lot of air in the pipe can significantly reduce the pressure.

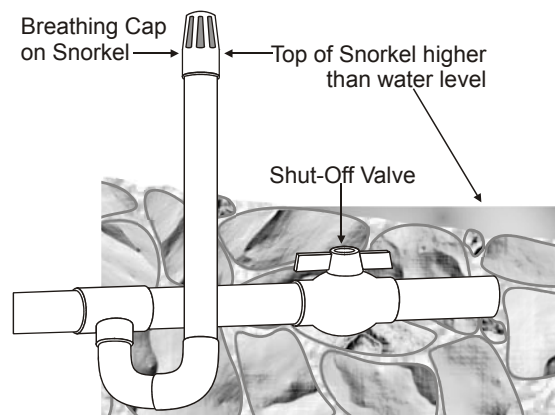

Filter Collapse

A snorkel or shepherds crook close to the filter may overcome the problem of the filter or the pipe collapsing from high suction. T junctions with valves to bleed the line at regular intervals along the pipe will help to solve the problem of silt or air in the line. If the pipe goes through the wall of the weir, it is suggested that you install a larger pipe for this short distance, in case you need to upgrade to a larger pipe size at a future date.

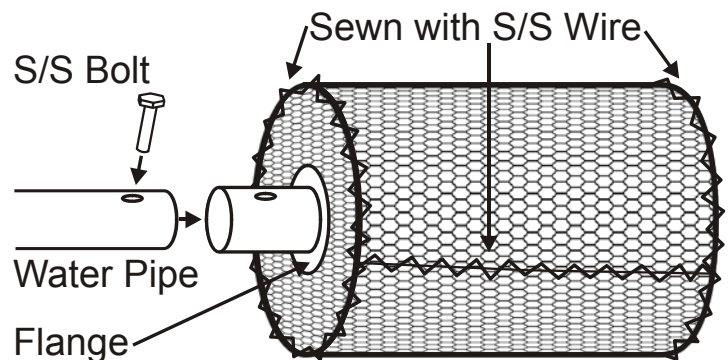

Pipe Siting - Layout

If at all possible, attempt to lay the pipe down a steep gradient immediately after the water source so as to develop sufficient pressure to overcome any humps or dips thereafter. Without such an initial gradient the suction can cause enlargement of air bubbles, collapsing of polypipe, and the suction of air through fittings. It is generally better practice to take the pipe down monotonically, ie with no humps and dips. Humps will tend to develop by themselves if any air is in the system as lower parts fill with water and lie lower, particularly if the pipe is on a soft surface, or hung between points like this:

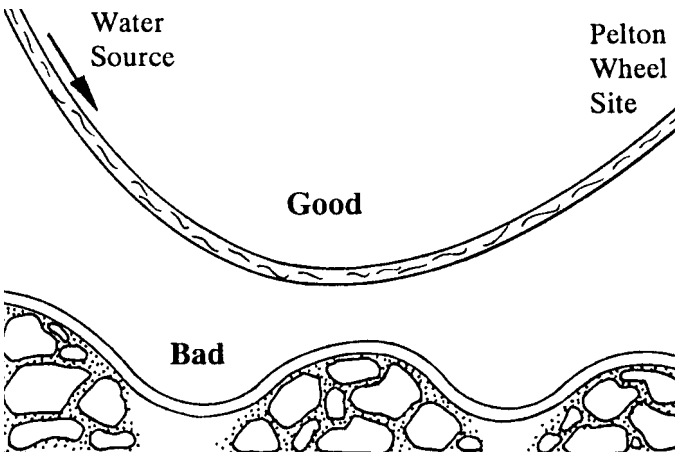

The diagram above illustrates how to lay a pipe so that air can get out the ends. Using a little extra length of pipe is better than having a pipeline which has a permanent air pocket losing head, or a pipe which keeps stopping.

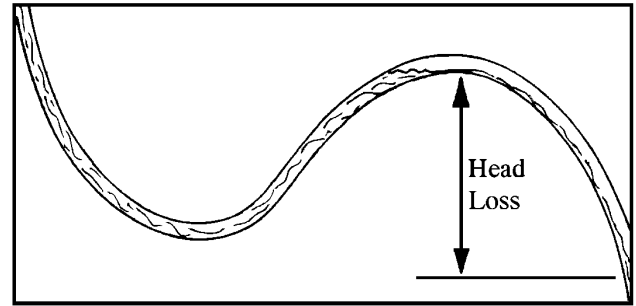
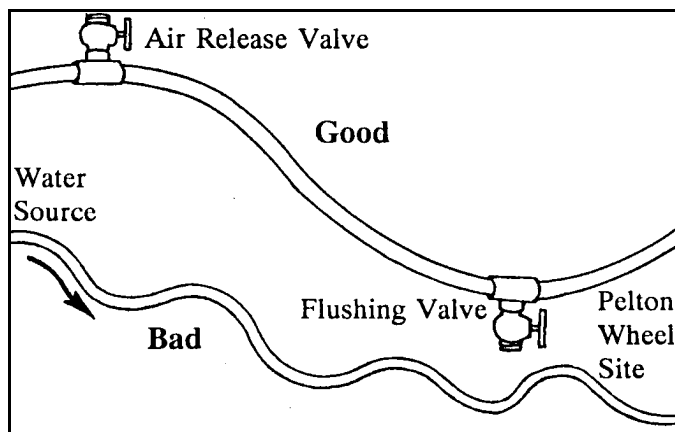

The drawing above illustrates a common problem. The head lost directly subtracts from power at the turbine whatever the water flow unless it is enough to entrain air and wash bubbles out of the line. Some pipes have insufficient gradient to achieve this flow rate, so the air lock remains as a fixture!

Even after all these precautions some pipes can refuse to start. Big pipes with slow gradients (1 in 10) are the hardest. One trick is to place joiners or "T" joints with gate valves every time there is an unavoidable hump as shown below. Successive flushing from the source down can start even the worst of pipe runs. Silt and gravel can also be so cleared out, but usually pipes are blocked by air pockets. Special fittings that automatically dispel air are available.

Syphons

Many people successfully run pipe intakes with a syphon as drawn below.

Systems like this are not necessarily self starting. If air gets into the pipe for any reason, such as exceeding the flow of the creek, turbulence washing bubbles into the intake, or dissolved air coming out of the water where the pipe lies in the sun, then the water can cease flowing and require complex measures to restart. Some of the methods used are:

1. sucking on the end of the pipe,
2. blowing into the end of the pipe,
3. driving water into the bottom of the pipe with a pump or another pipe,
4. wriggling the pipe,
5. filling the pipe with water using a bucket or another portion of pipe above the dam,
6. constructing a small dam so the inlet and first portion of the pipe are below the water level,
7. or simply leaving it alone in the hope that temperature variations will cause air in the pipe to expand and contract and start the syphon.

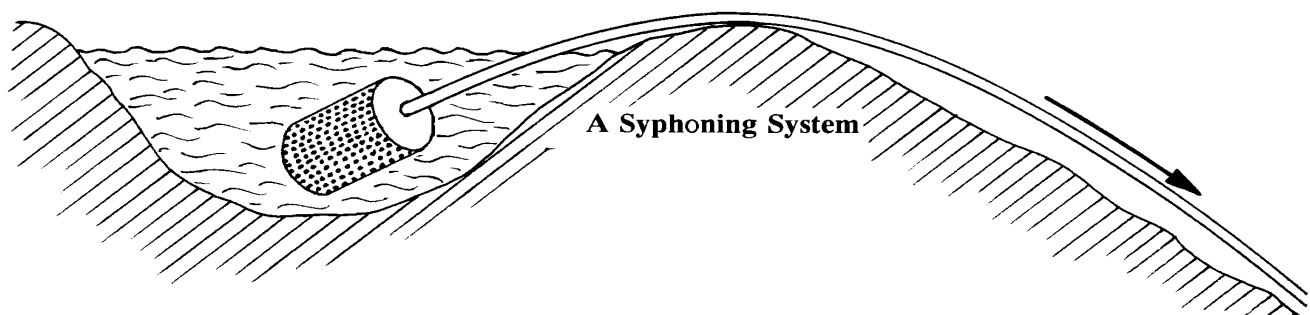

Floods

Don't locate the turbine on a flood plain! It is tempting to do this to get all possible head, but this is false economy. If the whole turbine has been inundated in flood water the most sensitive parts are the bearings. The generator windings withstand submersion quite well. Dry out the generator at the earliest opportunity as rusting quickly sets into the ball races, and the silicon steel laminations. Not much rust is needed to clog up the air gap and make disassembly a sledge hammer job! **A rusted generator can be an expensive and difficult problem to solve!**

Weeds

Grass can choke the generator fan and prevent rotation or obstruct cooling air. Unwanted tenants can take up residence. Black ants, slaters and cockroaches can get through small cracks and they all conduct electricity and leave remains which promote corrosion.

These problems can be avoided if the unit is housed in a small shed. This will also control that enemy of Micro Hydros - COWS! They trip over pipes and cables and horn strange objects in their paddocks.

Gate Valves

We will discuss in more detail that gate valves should be operated slowly to prevent water hammer. A surprising point is that they can actually be damaged if they are left turned off incompletely. Cavitation under the gate valve can eat away the brass so that they will leak forever. This is not a catastrophic failure, but it is irritating when water squirts everywhere while you are trying to screw on a nozzle. Please note that the hydro output should not be regulated by turning down the gate valve as this will cause cavitation. Refer to page 15 on how to select the appropriate nozzle(s) to regulate the output.

Water Hammer

If a pocket of air goes through the nozzle there is temporarily little obstruction to water flow and the often considerable mass of water in the pipeline accelerates. It is quite common to have 200 kg of water travelling at 20 kph. When this hits the obstruction of the nozzle there is a sharp pressure surge against the nozzle. This water hammer creates forces up to 10 times the static head of the water and can burst pipe junctions, break fittings, blow off the nozzle caps or burst the casing.

The best remedy is to operate valves slowly taking 20 seconds to turn on the water. Anchorage of the pipe is also an important factor. Whipping of the pipe is the most destructive effect so the end of the line should be terminated in some manner as below.

The anchorage point (clamp or tie) takes most of the forces transferred down the pipe which relieves stresses on the intake manifold.

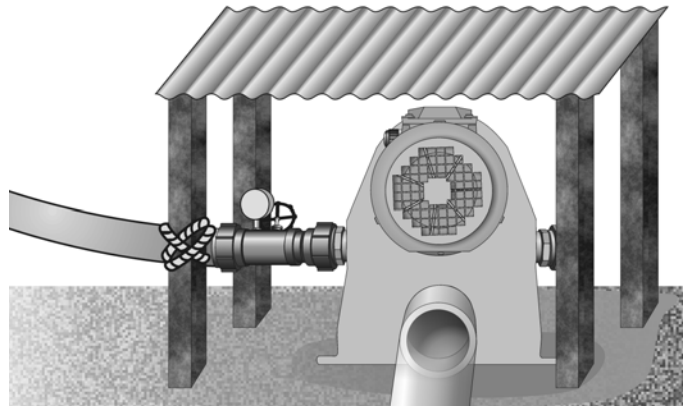

Outlet Drain Plumbing

If the turbine is sitting on gravel, rocks or concrete the water can simply fall out of the spray chamber and run away, but in most installations there must be a pipe attached to the outlet, or a gutter of some sort constructed, otherwise run-off water will cause nuisance or erosion. Land slides, road damage and noise can also be produced by uncontrolled outfall.

When using too small a pipe for the exit water (less than 100 mm ID) there is a danger of water not getting away fast enough from the spray chamber. This can cause flooding of the chamber and wetting of the generator. It is important to install the outlet pipe with as much possible fall or gradient. It should be kept clear of weeds etc and regularly checked.

Some installations catch the waste water by locating the turbine on top of a tank and use a float switch in combination with an electric solenoid valve to turn off the water when the tank is full. Beware of water hammer when using a solenoid. The solenoid should be placed at the hydro and not some distance away from it. If there are several households and/or an irrigation system using the water below then this may be a worthwhile measure to conserve water and at least still have some power during dry periods. There has often to be a compromise in the head used in order that the tank outlet is high enough to be useful. There may be in the order of 450,000 litres per day flowing into the tank if the turbine runs continuously.

Chapter 5 Electrical Wiring

AC Transmission

WARNING: The generator produces potentially lethal voltages. Any work on the transmission line must be performed by or under the supervision of a licensed electrician.

The electricity produced by the generator can be transmitted more than a kilometre with minimal loss. High voltage transmission is good from an efficiency point of view as there is very little energy loss. It is conventional to have the control box at the house or battery room so an eye can be kept on it.

Siting Considerations

The Micro Hydro should usually be located in the best place for plumbing, with the power transmission being treated as a secondary consideration. Electricity will go uphill without any resultant power loss!

Three phase wires and one earth wire of approximately 1.5mm², insulated to 600VAC standards are required. RPC recommend the use of sheathed insulated cable for ease of installation and maximum protection. Underground wiring is preferable, but properly installed overhead wiring is acceptable.

NB: All wiring should conform to Australian Standard AS 3000.

Lightning Damage

Overhead wiring is more susceptible to lightning damage than underground, but all transmission lines are vulnerable. Direct hits are rare, but nearby strikes can induce damaging voltages. The control box incorporates reasonable protection, provided correct earthing procedures are followed.

It is important for the earth connection (on the rear of the hydro control box) to be grounded and that the green and yellow cable be connected to the earth screw inside the generator.

Proper earthing will ensure consumer safety and proper operation of the lightning surge protection.

Lightning protection is a complex issue. Refer to Australian Standard AS 1768.

Connecting Hydro to Control Box

Connection to the control box is through a 4 pin plug and socket. The plug should be fitted to a flexible 600V rated sheathed lead as shown in the diagram.

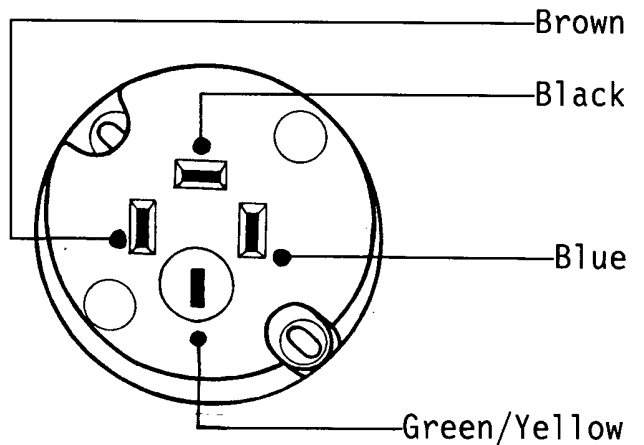

The colours shown are for IEC standard cables. Connection to the generator is made in the integral conduit box, which is part of the moulding of the generator housing. The wiring diagram below is the "star" configuration as wired at the factory. It is the best wiring configuration for sites less than 50 metres head.

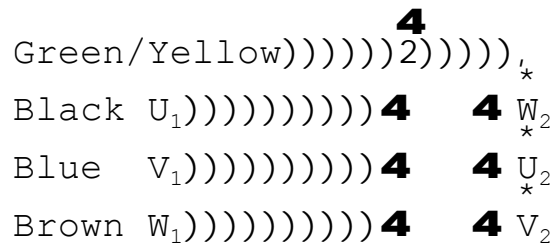

If your site has greater than 50 metres head, then we recommend a "delta" configuration as shown below. This will improve the performance of your hydro with greater than 50 metres head.

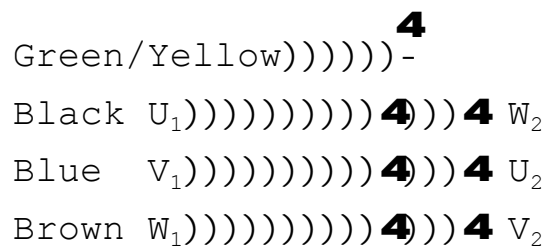

Short Circuit Protection

Short circuits either in the DC or the AC supply from the turbine will cause the generator to simply de-excite and pass only a small current into the short. When the short is removed the voltage should immediately come back up and damage is unlikely to have been caused. For this reason a disconnection switch is not needed on the wires from the generator. If the plug is pulled out of the control box then the generator ceases producing voltage after about 0.1 second.

The connection plug appears to be the wrong gender, but this is intentional as there is a chance of a shock from charge remaining on capacitors in the control box after the generator is disconnected.

NB: All wiring should be completed to the appropriate installation clauses of Australian Standard AS 3000.

Load Dump

This finned aluminium heatsink disposes of surplus power by converting electrical energy into heat and dispersing this heat into the surrounding air. Note that the load dump is a 750W 240V hot water heating element and any alterations to this must be carried out by a licensed electrician. The voltage on the blue and brown wires can be as high as 370 volts DC, so correct installation and care is needed. It is tempting to connect the dump circuit to some low priority useful 240 volt load such as a water pump. This will not usually work as the dump is DC at varying voltages.

WARNING:
The Load Dump gets hot during normal operation.
Mount securely in upright position.
Ensure free flow of cooling air.
Keep out of reach of children.
Keep flammable materials away

The load dump needs to be installed upright to encourage chimney effect. Cobwebs or anything obstructing free air movement around the Load Dump should be periodically removed. It can be located in a drying cupboard if you wish to use the surplus heat energy.

Note: the hydro Load Dump can only control energy from the turbine. Surplus energy from other power sources connected to the DC circuit (eg solar panels) cannot be disposed of by the hydro Load Dump, because the dump works at a high DC voltage before the power is converted to the lower DC volts.

WARNING: The Load Dump connects to a Lethal Voltage. Do not disconnect when hydro is running. Any alterations to the Load Dump must be carried out by a qualified electrician.

DC to Battery

Connecting Control Box to Battery

The Control Box has a junction box for connection to the battery (of whatever voltage the control box is designed for). Connect the (red "+") terminal on the control box to the positive terminal of the battery and the negative (black "-") terminal to the battery negative using suitable insulated copper wire. Refer to Appendix F for cable sizing.

Battery negative is normally earthed to reduce electrical interference and to ensure that the battery does not become live with respect to earth as a result of faulty power equipment. Refer to Australian Standards AS 3000 and AS 1768.

Setting of In-built Regulator

The regulator supplied with the Rainbow Micro Hydro is normally set for the hydro to function correctly under average conditions. There are a few settings that should not be altered. For the micro-hydro the regulator must only ever be used in program 4 mode. The PWM (pulse-width modulation) setting should be at 2 and the LSET which controls hydro power dumping must equal 10. Leave BSET at 0 and use the voltage setting recommended for your battery type. Refer to the regulator reference manual for detailed regulator information.

Interaction with other Regulators

The hydro generator may be used in conjunction with other forms of energy production on the same battery. However, correct connection of this equipment and associated regulator depends on several factors.

If another charging source forces the battery voltage above that set on the hydro regulator the control box will initiate a full dump causing the generator to de-excite. The turbine becomes unloaded allowing it to exceed normal operating speed. This may damage the unit, creates excessive noise and should be avoided.

Switching Regulators

Some types of solar switching regulators will cause this de-excitation to occur cyclicly each time the panels are switched on. The interactions are quite complex and vary with battery type, state of charge, solar array size and hydro power output.

Placing a suitable diode between the hydro and battery will prevent the interaction, but at a cost of energy lost in the diode. Also the voltage drop (typically over half a volt) will cause the hydro voltage meter to read slightly above the real battery voltage.

Shunt Regulators

Shunt regulators also show various problems with interaction. Care must be taken to ensure the hydro energy is not dumped by the solar shunt regulator unless it is large enough to control both the solar and hydro input. Small shunt regulators may be protected by a diode. Connect the solar shunt regulator to the panels and feed the power to the battery through a diode as shown. This will cause an error equal to the diode drop between the regulator voltage and the true battery voltage. When a diode is used in this way the blocking diodes supplied with some solar panels are not required.

Regulators supplied with wind generators are generally a shunt type. These are best treated similarly to small solar shunt regulators by connecting the generator and regulator and feeding the power through a diode to the battery.

If you are having difficulty combining the hydro with other systems please contact your dealer for advice. Our technical staff will also be happy to help if you contact us directly.

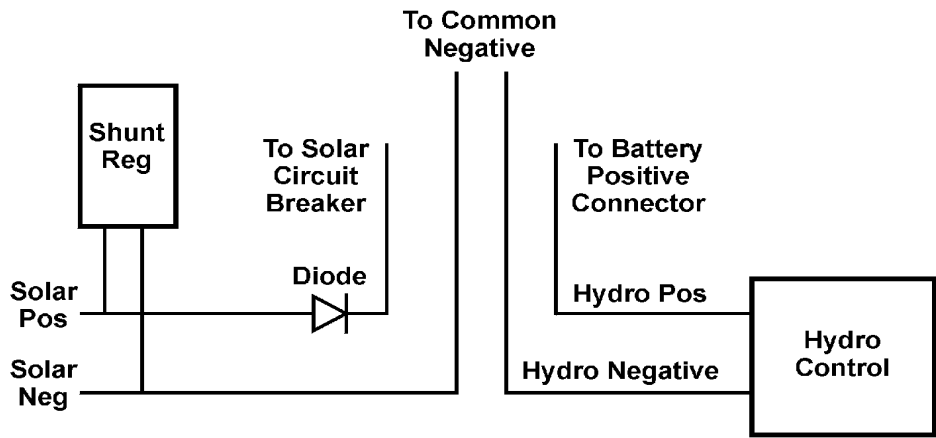
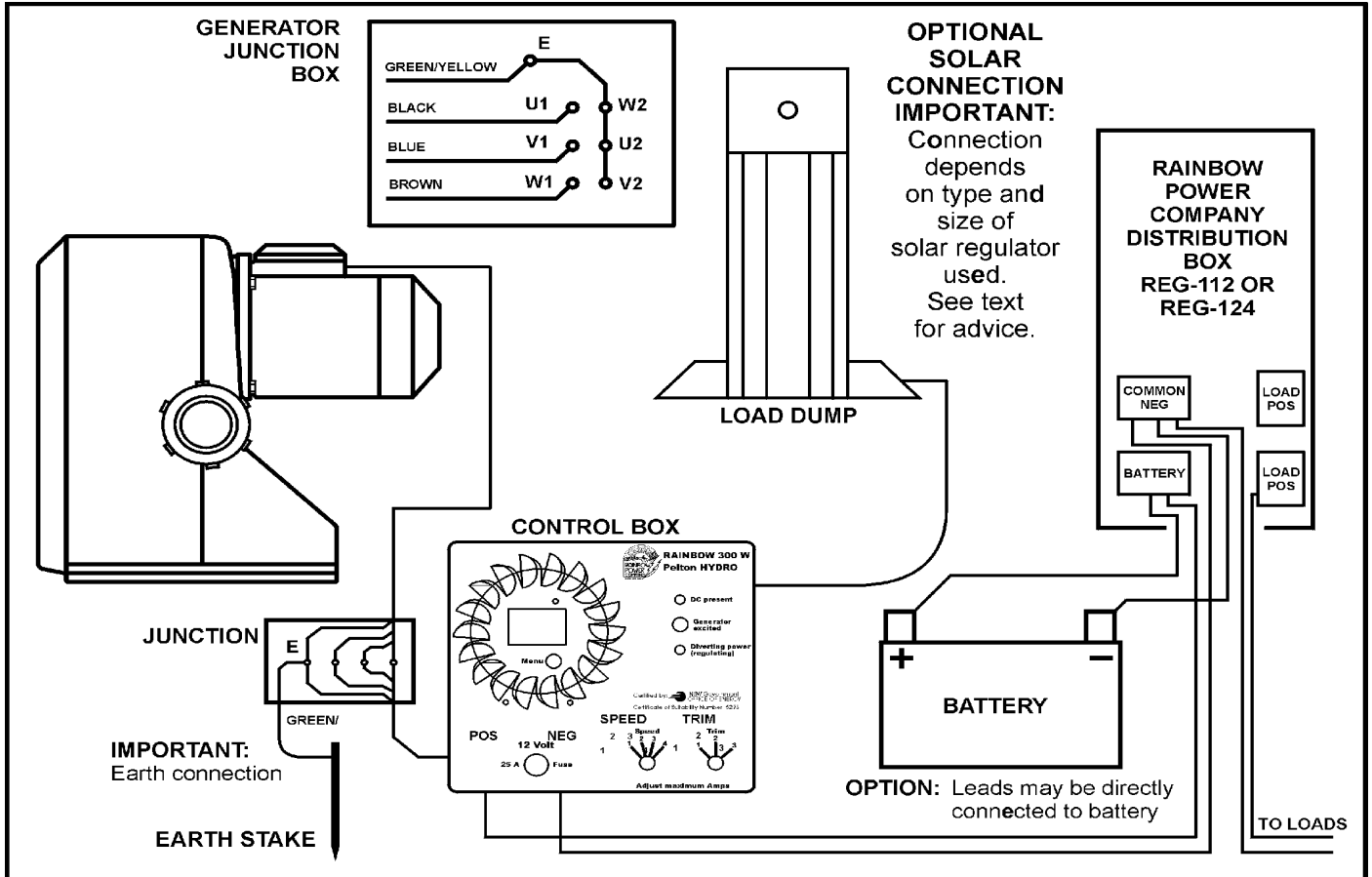

Connection to Prevent Shunt Regulator Damage

Note: Shunt regulator will read higher than battery voltage.
 Diode must be rated for solar array (or wind turbine) current.
 Hydro regulator should be set slightly above shunt regulator voltage.

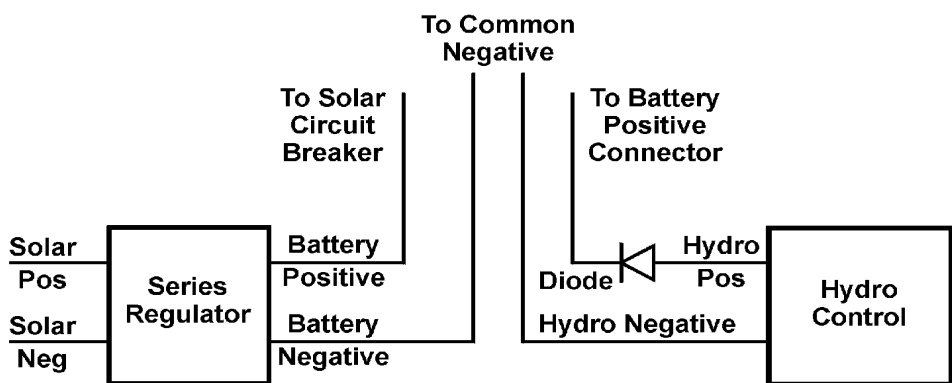

Connection to Prevent Hydro De-excitation

Note: Diode must be rated for hydro current.
 Hydro volt meter will read higher than battery voltage.

Solar / Hydro Hybrid System

You do not need a separate solar regulator if you have both a solar array and a Rainbow Micro Hydro system with the built-in regulator with the digital (LCD) display. Instead of a separate solar regulator you can use a 40A solid state relay (Cat.# RGX-R40) that can be turned on and off by the built-in regulator in the Micro Hydro. If you also incorporate a shunt and a shunt interface, the hydro regulator can then monitor all of your solar input. You can also incorporate a second shunt and shunt interface to monitor all of your power usage (DC and inverter usage) as well. The advantage of this approach is that you have only one regulator that monitors everything and can give you the complete results of your entire power system without needing to add or subtract the results of one LCD readout from the results of another LCD readout.

Total System Control: The built-in regulator in the Micro Hydro can also be used to regulate a wind turbine, monitor all DC and inverter loads and even control a back-up generator, turning it on when the battery voltage goes too low and off again when sufficient charging has been accomplished. All of these parameters are programmable. Refer to the Plamatronics Reference Manual.

Note:

1. Blocking Diodes will be required in the Solar Array.
2. A special cable connection will need to be ordered from Rainbow Power Company to connect the Plamatronics Shunt Interface (Cat.# RGX-001) to the regulator connection inside the Hydro Control Box. The standard cable (Cat.# RGX-222) will not suit.

The following diagram doesn't show a DC Distribution Box which will be required if DC circuits are to be incorporated into the system.

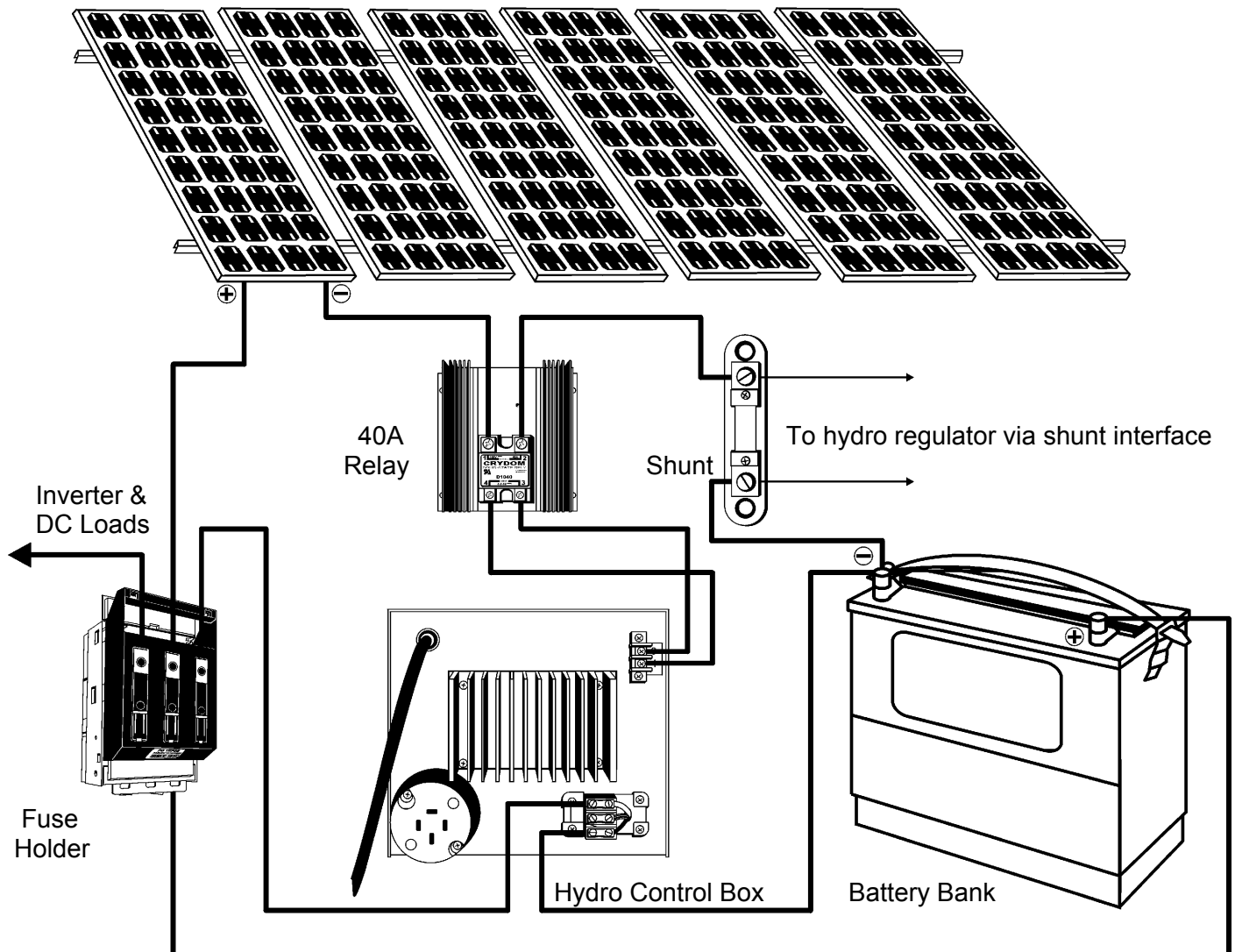

Solar / Wind / Hydro Hybrid System

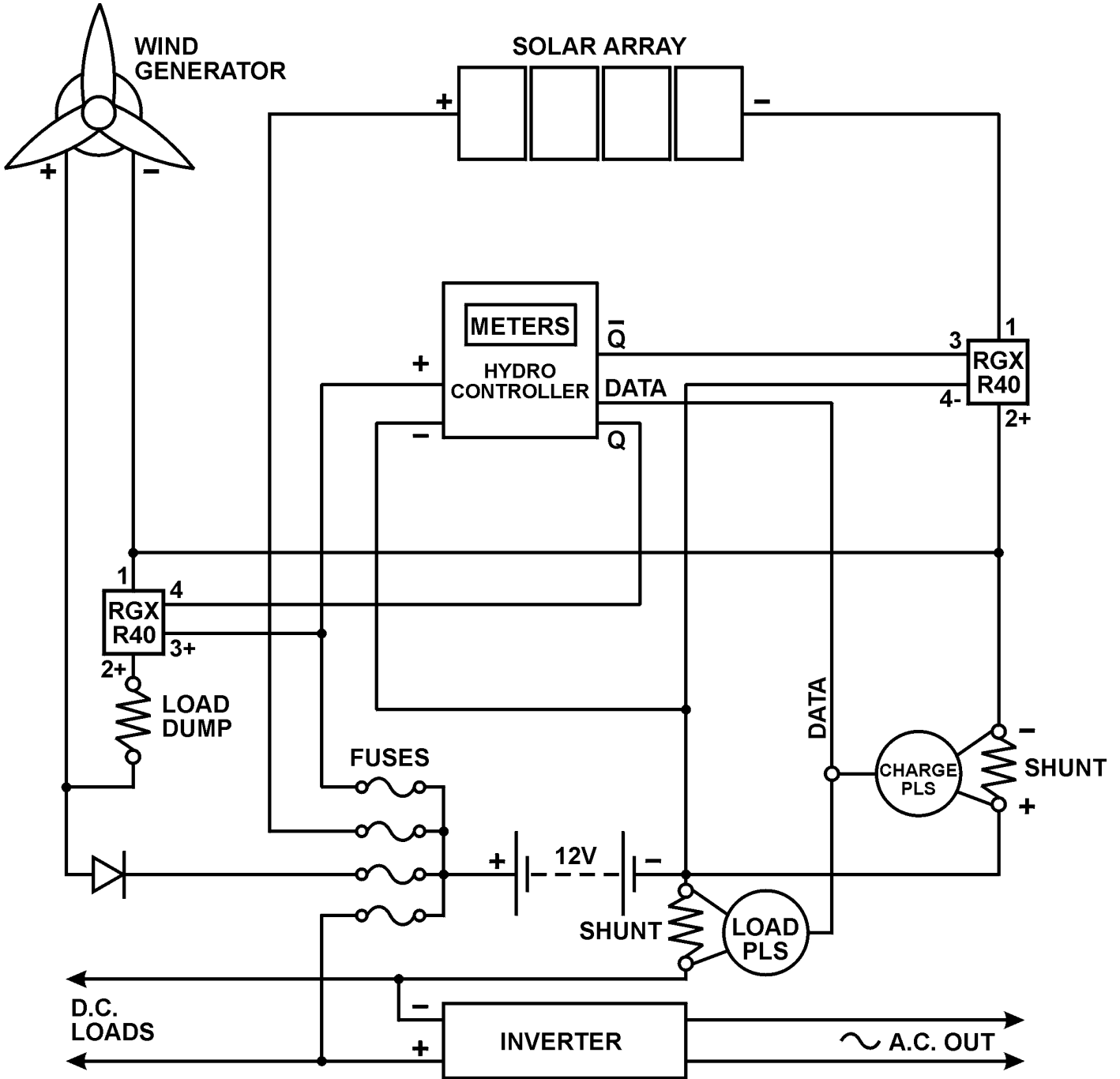

Chapter 6

Adjusting Micro Hydro

Nozzles

The Rainbow Micro Hydro has 2 nozzle locations. The maximum nozzle size is 18.1 mm diameter, so to get more water on the wheel at low heads we have used two nozzle locations. To get maximum power with a dynamic head of less than 25 metres you are likely to need to use two nozzles. If you wish to either increase or reduce the water throughput or power output, refer to the nozzle sequence listed in Appendix E.

It may seem that the bigger nozzle will give more power, but this is true only up to a point. The benefit of more water consumption can be offset by reduced pressure if your pipeline is insufficiently large (see graphs page 22 and 23 and head loss table page 24). There will be an intermediate nozzle size which gives best power. The pressure gauge mounted on the gate valve will indicate failing pressure when too big a nozzle or too many is/are being used, or if there is some other pipeline problem. Lack of water, blocked filter, or persistent air locks will all reduce the pressure.

Note: Do not attempt to regulate the hydro output by partially closing down the gate valve as this will make the hydro extremely inefficient and cause cavitation and eventual failure of the gate valve. Hydro output should only be controlled by changing the nozzle(s).

Sample Flow Rates

Nozzle Size(mm)	Dynamic Head		
	15m	50m	80m
	Approximate Flow Rate (litres/second)		
2.3	.07	.13	.16
3.2	.14	.25	.32
4.5	.27	.50	.63
6.4	.55	1.01	1.27
7.8	.82	1.50	1.89
9.0	1.09	1.99	2.52
11.1	1.66	3.03	3.83
12.8	2.21	4.03	5.10

Power Limit: WARNING

If your site has good pressure and you have a generous pipe, it is possible to exceed the power rating of your Micro Hydro unit. This will cause the fuse to blow. If you install the wrong fuse you may do damage to generator or electronics. When first setting up the unit, start with a small or medium nozzle and watch the ammeter. With the voltage setting turned up to maximum, ensure that the amps don't go higher than 20 on the 12 volt model or 10 with the 24 volt model. There will be a maximum safe nozzle size, so take all nozzles larger than this and HIDE THEM! (Or send them back to Rainbow Power Company).

Control Knobs

The speed and trim knobs are to adjust the hydro to the site. With the unit operating adjust the knobs to achieve maximum amps (see below).

Turbine Speed

After selecting the correct nozzle(s), the control knobs on the control box can be adjusted. The "SPEED" knob matches the turbine speed to the water speed. Efficiency is best when the speed is nearly half that of the water, so higher speeds match with higher pressures. Select one of the four positions on the switch which gives the most amps.

Generator Voltage

The trim knob can now be set. Its function is to find the optimal generator voltage which depends on speed and power level. There are three marked positions on the switch with distinct clicks between positions which are not connected to avoid shorting the control box if the switch is operated while the generator is running. We recommend against rapidly switching between positions. The lower positions will allow more output at low power levels, while the higher positions will give more output from greater power levels.

Simply set the knobs for maximum amps. It is quite likely that position #1 will be best with a small nozzle, while position #3 may yield several more amps when a big nozzle is installed.

Visual Adjustment

You can see at a glance whether the turbine is running at an efficient speed. The water will come off the wheel with minimum speed and sideways near the axle. If it continues forward as if straight through the wheel, then the wheel is too fast. If it deflects back towards the nozzle then it is too slow. The noise will also be low at optimum speed. Note that the trim knob will also affect the turbine spray pattern.

Regulator

During the adjustment of the speed and trim knobs there may be a limitation due to the fact that the battery is fully charged. The amp meter shows current into the battery which will be reduced if the unit is regulating. When making these adjustments, the red regulating light should be off. Turn on some loads, if necessary, to reduce the voltage so that you have a full charging current to work with.

Refer to Plasmatronics Regulator Reference manual for information on the inbuilt regulator. If another shunt regulator is used to regulate your solar input for example, it is important that it is protected from the hydro output with a diode on the positive line (as per diagram).

Some "argument" may be seen between the hydro regulator and other regulators on the system (eg solar regulator). This erratic cutting in and out will not do any harm, setting the hydro regulator above or below the other will make it stabilise. Contact RPC for further advice if needed.

The generator will charge a battery up to the float voltage set on the regulator. The best float voltage depends on the type of battery, its condition and use regimen. This should be discussed with your battery supplier. For a 12V bank we recommend about 13.5 to 14 volts for lead-acid batteries and 14.5 to 15 for nickel cadmium batteries.

Output Power

The power you can expect is indicated by the graphs on page 23. Depending on the operating point (head and flow at your site) the wheel is about 70% efficient, the generator about 75% and the control box and rectifier about 85%. The overall efficiency is the product of all 3 figures at every operating point. 40% efficiency is not achieved over a very big range of head and flow. Our machine excels in the enormous range of head and flow over which it will work. Most hydro-electric systems perform very badly at low power levels and many published performance graphs are extrapolated rather than measured data.

Meters

Both the output voltage and current are displayed on the LCD meter so that electrical performance is easily seen. You can also see the accumulated power input over the day or check all of these performance criteria over each of the last 30 days.

Indicator Lights

DC Present (Top Green Light): This light is on whenever there is DC voltage present in the Control Box. This is an indication that the battery bank is connected and the fuse isn't blown.

Generator Excited (Centre Orange Light): This light indicates that the generator is excited. At low generator speeds it will flicker with the cycles. This is normal.

It may extinguish while the machine is running on position 1 of the trim knob when the battery is under 10 volts. It will extinguish if there is insufficient speed for build-up of the magnetism. This is altered by the speed knob. Any other failure to excite will also be indicated, such as shorted or open wires to the generator, slipping wheel, shorted transistors in the control box or load shed circuit, shorted output, clogged jet in nozzle, etc. A failure to excite may not necessarily indicate that a repair is necessary as it may be due to loss of residual magnetism of the motor. Refer to the second paragraph on page 29 for instructions on reinstating the residual magnetism.

Diverting Power – Regulating (Bottom Red Light): This light indicates when power is being dumped in the Load Dump. The amps on the amp meter will decrease when this light is on.

Fuse

The fuse holder used requires the 3AG type fuse with a small amount of grease, petroleum jelly or other means of protection against tarnishing and developing a bad contact. For the 12 volt unit this should be a 25 amp or for the 24 volt unit a 15 amp. Oversize fuses will fail to protect the electronic circuits.

Note that the fuse will NOT blow if you short circuit either the DC output to the battery or the high voltage output between the generator and the control box. Induction generators inherently will not pass much current into a low voltage (such as when there is a short circuit) as they lose excitation.

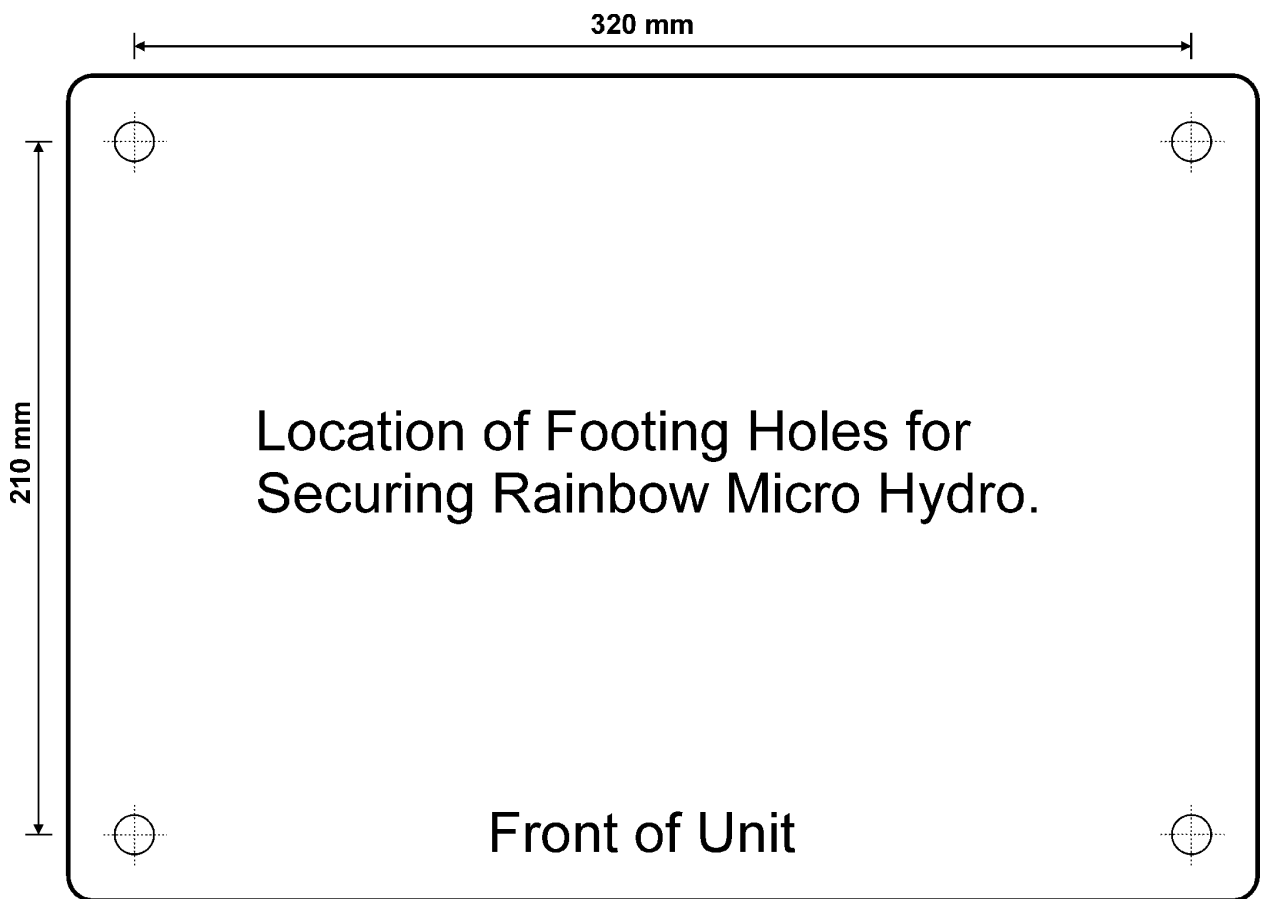
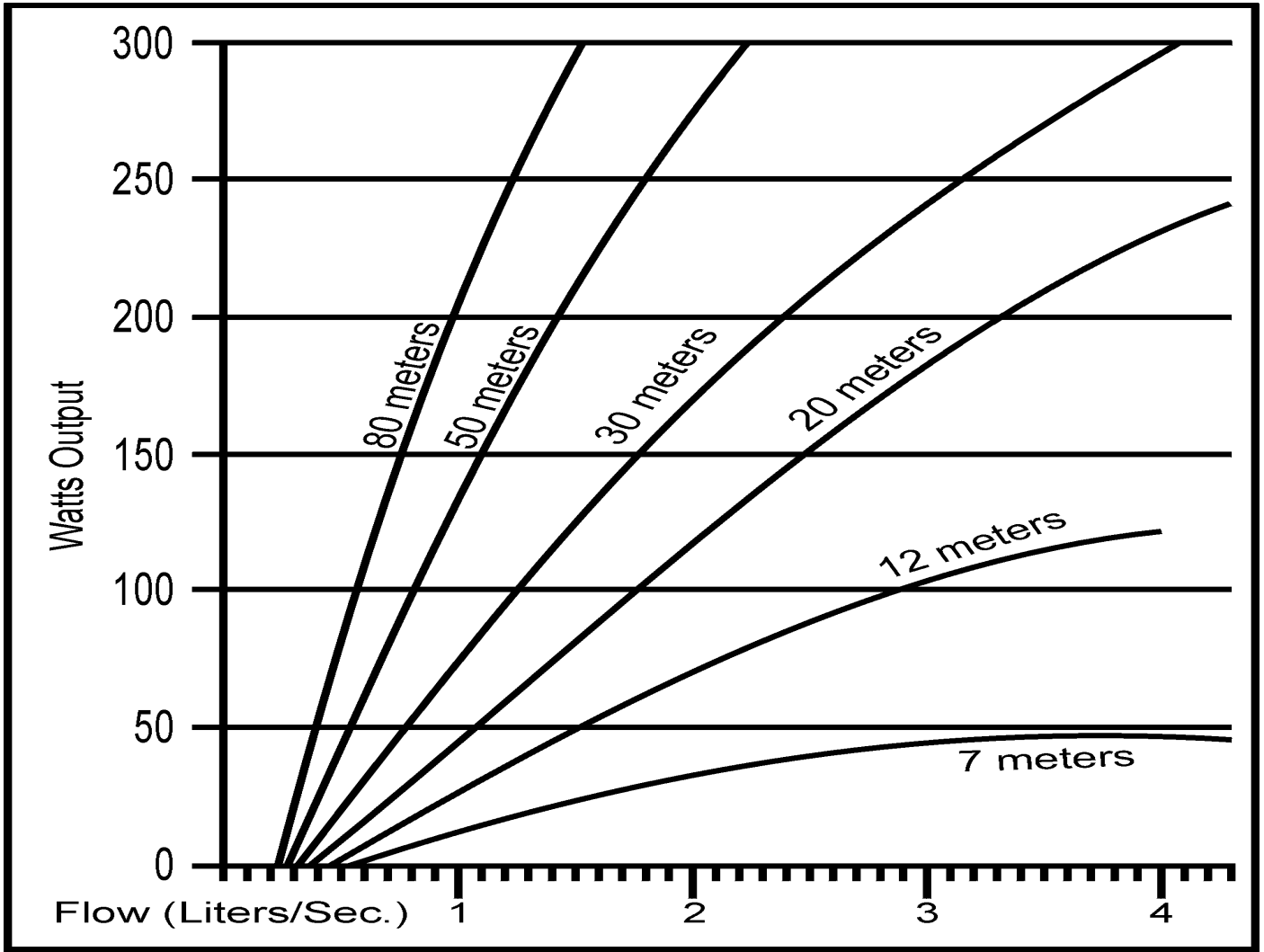

Chapter 7

Disassembly and Routine Maintenance

Load Dump

Warning: When the turbine is running, the wires to the load dump carry a dangerous voltage. Any work performed on the load dump should be carried out by a qualified electrician. Shut the turbine down and disconnect the battery before any disassembly is carried out.

You will find the Load Dump connected by a high voltage cable. If you need to disconnect this, the junction block may be accessed by removing the base from the heat dump. This reveals the wire terminals on the element. The green and yellow wire is meant to be connected to the case of the element. Do not connect it to either of the live pins!

It is essential that the machine is not run without the dump being connected, so screw the wires into the connector block carefully, making sure that the plastic coating on the wire is not preventing electrical contact.

Runner

The pelton wheel runner itself can be removed with a screwdriver and spanner to fit a 6 mm nut. The plastic of the runner is intentionally hard so as to resist sand which may be present in the water, and to help to reduce fatigue with age. This makes it brittle!

After long periods of time, the pelton wheel assembly may become hard to remove from the motor shaft. Take care not to damage the pelton wheel. If the assembly cannot be removed by gentle persuasion use the following instructions to remove the assembly safely.

1. Carefully study the diagram on the next page.
2. Find a suitable piece of timber (minimum 40mm thick) to use as a "pulling block". Ensure it will not damage the window seal, and drill a 10mm hole through the centre of it.
3. Remove the clamps, window and long 6mm bolt that secures the pelton wheel assembly.
4. Place a pile of rags or similar inside the spray chamber to soften any accidental dropping of the wheel. **NB The pelton wheel is brittle and the shaft may release suddenly during this exercise!**
5. Insert the long 10mm bolt supplied with your hydro through the wooden pulling block and carefully screw it into the end of the pelton wheel shaft until the bolt head starts bottoming on the wooden pulling block. Slowly continue to tighten the bolt until the pelton wheel assembly is pulled off the motor shaft.
6. Once the assembly is removed, use a wooden drift to separate the wheel from the shaft by gently tapping the shaft through the centre of the pelton wheel.

Generator

Once the runner bolt has been withdrawn the generator can be unbolted and removed. The bearings can be accessed by unbolting the end bells from the generator. Tap the bells off with a drift and don't use a screwdriver to open up the crack as the very tight fit will be interfered with. This will upset the close air gap of the motor which could compromise build-up of voltage. The bearings can be removed from the shaft if necessary with a puller.

Maintenance of Bearings

The generator has a bearing housing of the fully enclosed type without lubricating nipples. The lubrication carried out prior to delivery is sufficient for several years service. The bearings should also last for several years. We suggest that the maintenance below be carried out by a mechanic or fitter.

Before fresh grease is added, the bearing housing must be opened and cleaned of all old grease and traces of soap, which constitute the broken-down products of the grease.

Type of Grease

A multi-purpose lithium based grease is recommended such as SHELL ALVANIA EP2, or CASTROL EPL2.

Reassembly

When reassembling the generator a small amount of grease on the machined surfaces of the bells will allow a more easy fit. Some people heat up the bells a little to facilitate assembly.

The only wearing parts in normal use are the two generator bearings. These are easily available ball races.

The thrower behind the runner is efficient enough to keep the shaft quite dry and the only way water will get on the front bearing in normal use is through condensation while the machine is not running. This will evaporate when the machine is run as the generator produces warmth and air movement.

When re-assembling the pelton wheel assembly, ensure that all surfaces are clean and liberally apply a high quality anti seizing compound before re-fitting.

Window Clip Adjustment

If the viewing window is a little bit loose (because the foam band has compressed) then tighten each clip that holds down the window by ¼ turn (or as necessary). Do not overtighten, as this could cause distortion of the window and the seal and cease sealing properly.

Plumbing

The quick connect intake manifold makes for very easy assembly of the fittings on the end of the penstock (pipeline from creek). The gate valve supplied has a pressure gauge installed on the penstock side of the gate valve. This means that with the gate closed it reads static head and with the gate open it reads dynamic head. If this is less than 70% of the static head it indicates either too many nozzles or too large a nozzle is being used, or a loss of pressure due to a blocked intake filter, or air locks.

Changing Nozzles

When changing nozzles be very careful that the new ones sit properly on their pedestal. If the nut does not screw down all the way it can be ejected by a pressure surge and hit the wheel, so breaking off a cup. A less catastrophic error is the nozzle not being aligned. The water jet will then not be aimed correctly and water leaking around the rim of the nozzle could hit the jet of water and spoil its focus as well.

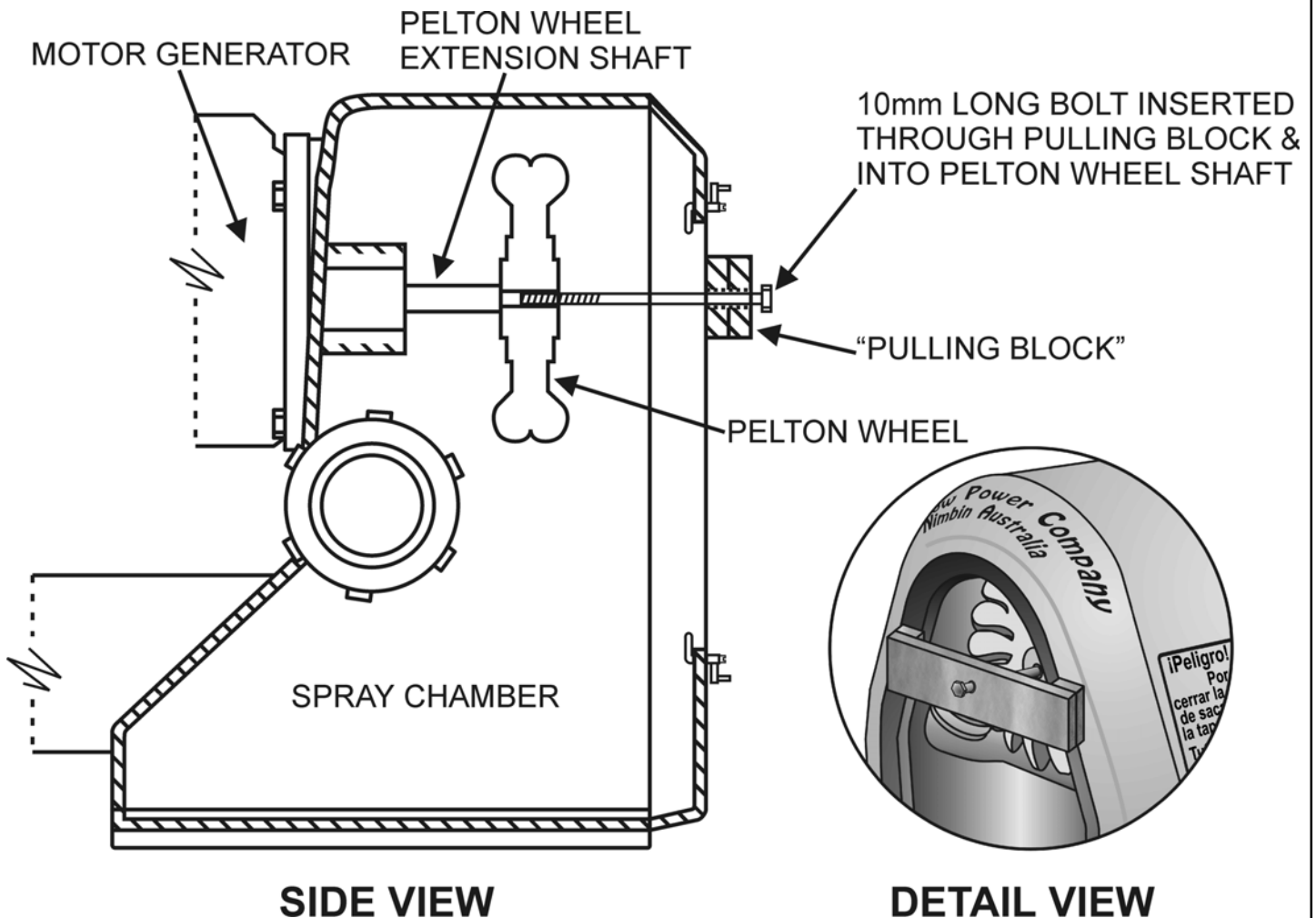

Diagram Showing How to Remove a Stuck Pelton Wheel

Chapter 8 Trouble Shooting

If the Micro Hydro unit stops charging, it is not always obvious which part of the system is at fault. It could be the water supply, mechanical problems, electronic problems, or cable faults. We have built into our machine a number of indicators to help locate problems quickly. As indicators themselves are prone to failure, we have also gone to some effort to protect them from the hostile environment in which they must work for many years.

The flow chart on the next page shows the questions you must ask, and the information you must use in arriving at a diagnosis of the problem. We start with the assumption that there is no power being generated by the Micro Hydro unit, ie there is no current flowing in the output wires. Go to the centre of the chart where it says START.

FLOW CHART FOR FAULT FINDING

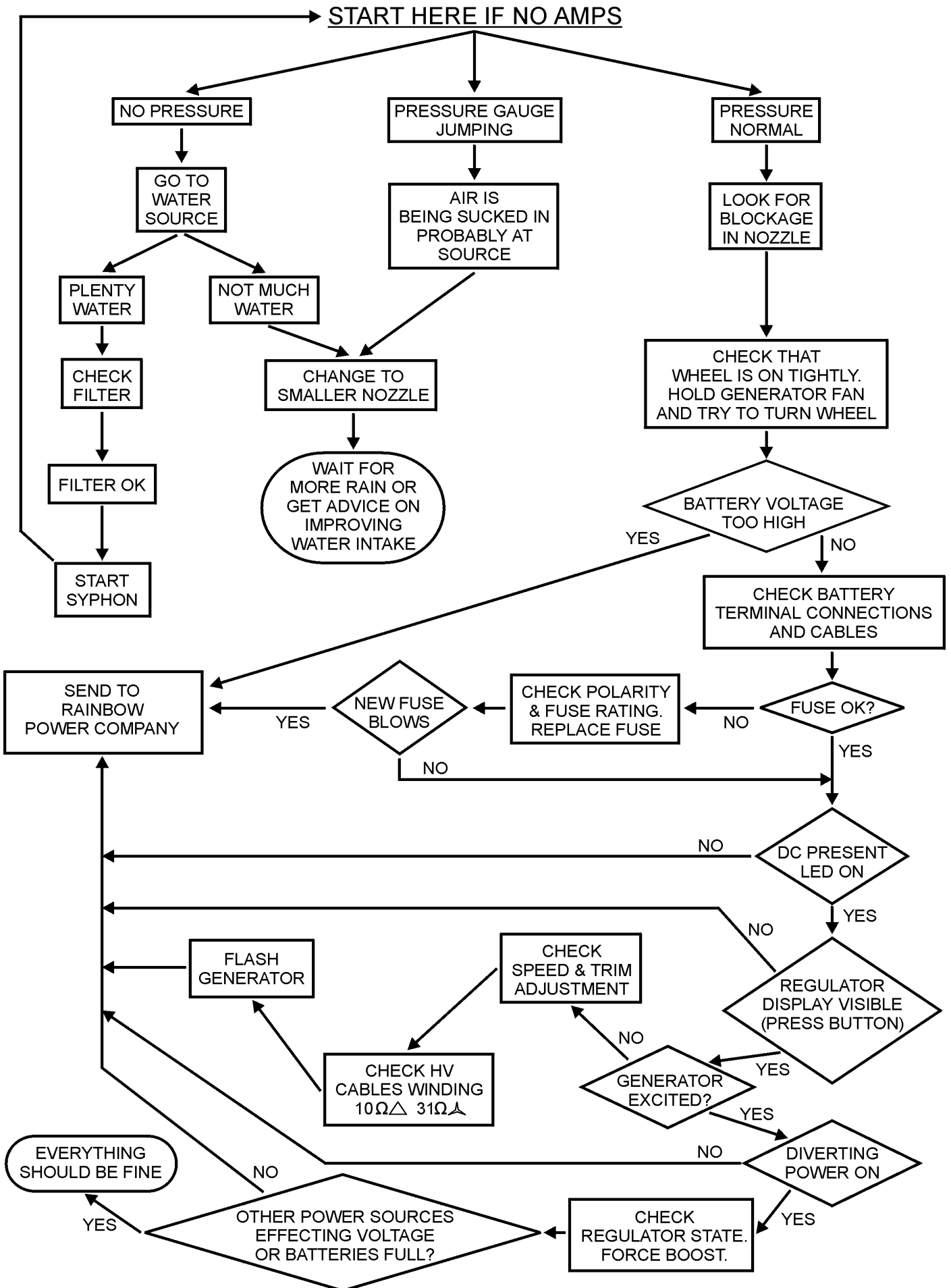

Appendix A

Site Considerations

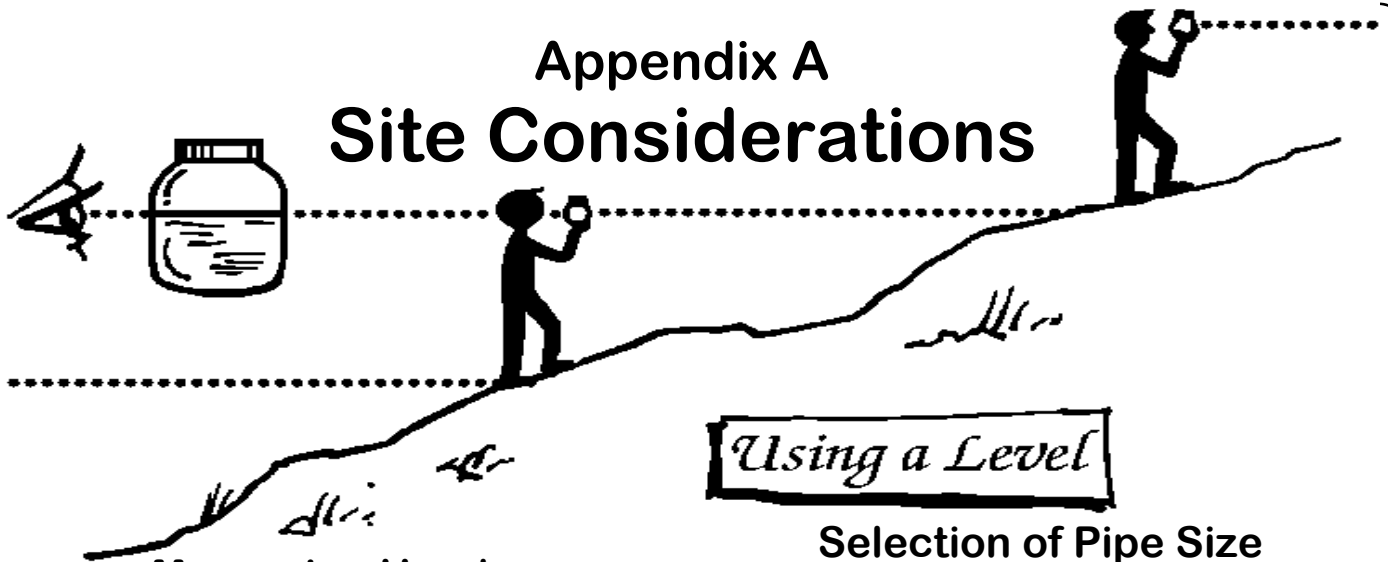

Measuring Head

The height of the water source vertically above the turbine site can be assessed by:

1. Reading a contour map in hilly country. Contours are usually drawn in every 10 metres of altitude.
2. If a pipe already exists then a pressure gauge connected to the end of the pipe will give the height: just divide the reading in kPa by 10 and you will get the head in metres. The size or length of the pipe makes no difference to the pressure, so long as it is totally full of water and there is no water flowing through it (ie a tap on somewhere).
3. Alternately, the head can be measured by walking up the water course with a spirit level. Hold the level with the bubble central and look along the top edge. The patch of ground you sight is the place you stand next. The number of times you do this before arriving at the source multiplied by the height of your eyes (say 1.7 metres) will give the head. In very rough country the head can be estimated by comparing the height of rapids and waterfalls with adjacent trees, or by hanging a rope over!

Quite accurate altitude measuring devices can now be bought. Electronic devices that look like pocket calculators are used by surveyors and measure differences in height down to one metre. Similar devices are used by glider pilots and are called altimeters. The elevation of the turbine site is subtracted from the elevation of the water source to obtain the available head. Rainbow Power Company staff are available to perform site assessments.

Measuring Flow

The flow of water in a small stream may be measured by taking a plastic bucket (10 litres) to a small waterfall or narrows in the creek and timing how long it takes to fill. Try to direct the entire creek flow into the bucket.

A 10 litre bucket filled in 10 seconds means one litre per second, which is a practical flow. This measurement should be made at a time when the flow is average or in the dry season and not just after rain.

Using a Level

Selection of Pipe Size and Calculating Friction Loss

Friction of water in pipes varies enormously with pipe size. Double the pipe diameter gives you 20 times the water! Another way of saying this is that one pipe size too small gives you half the electricity, and one size too big wastes considerable amounts of money on pipe.

What is the optimum pipe size?

1. Measure available (static) head by any of the methods as set out above.
2. Work out the length of pipe needed. Measuring or pacing out the distance is the most reliable, but if the country is really rough you may have to use trigonometry!
3. Use the pipe size recommendations as set out on page 22 or contact Rainbow Power Company for performance predictions for given or advised pipe sizes.

NB: If your available head is in the order of 7 metres, any loss will cause disproportionate power loss as the generator efficiency is failing below this pressure.

Estimating Electrical Output

Now that the flow and the static head are both known, the dynamic head can be calculated by subtracting the friction losses of the pipe (relative to flow rate, pipe length and pipe diameter). The output from the machine can be read from the graphs on page 23. At the Rainbow Power Company we have a computer program to calculate the theoretical hydro performance for you.

If the hydro unit will produce four amps at 12 volts or 2 amps at 24 volts and accumulating over a 24 hour period each day, it will compete with more than four solar panels in most sites (roughly equivalent monetary value) and charging when the sun isn't out! Less power may still be valuable when you consider that the hydro can run 24 hours per day in overcast periods when solar panels may not produce much power at all.

Suggested Pipe Diameters (OD)* for Rainbow Micro Hydro

* OD = Outside Diameter, assuming the use of standard metric polyethylene class 6 pipe.

Pipe Length (metres)	Head (metres)															
	13	15	20	25	30	35	40	45	50	60	70	80	90	100		
40	90	75														
50	100	90	63													
60	100	90	63	50												
70	100	90	63	63	50											
80	100	90	63	63	50	50										
90	100	90	63	63	50	50	50									
100	100	90	75	63	63	50	50	40								
120	100	90	75	63	63	50	50	50	40							
140	125	100	75	63	63	50	50	50	50	40						
160	125	100	75	63	63	50	50	50	50	40	40					
180	125	100	75	75	63	63	50	50	50	40	40	40				
200	125	100	90	75	63	63	50	50	50	40	40	40	32			
250	100	90	75	63	63	63	50	50	50	40	40	40	40	32		
300	100	90	75	75	63	63	50	50	50	40	40	40	40	32		
350	90	75	75	63	63	63	50	50	50	40	40	40	40	40		
400	90	75	75	63	63	63	50	50	50	40	40	40	40	40		
450		90	75	63	63	63	63	50	50	40	40	40	40	40		
500		90	75	75	63	63	63	50	50	40	40	40	40	40		
600			75	75	63	63	63	50	50	40	40	40	40	40		
700				75	75	63	63	63	50	50	40	40	40	40		
800					75	63	63	63	50	50	40	40	40	40		
900						63	63	63	50	50	40	40	40	40		
1000							63	63	50	50	40	40	40	40		
1500								63	50	50	40	40	40	40		
2000									63	50	40	40	40	40		

Suggested Polyethylene Pipe Diameters (mm OD) for Rainbow Micro Hydro

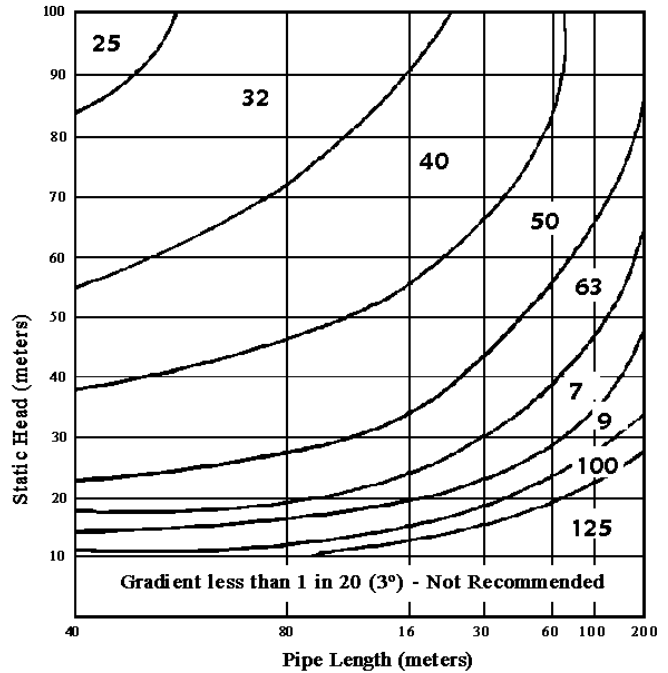

Note

All the above pipe diameters are in millimetres (outside diameter) class 'B' polyethylene. The sizes are to give between 90% and 100% of maximum 300 W performance.

Where near maximum performance from the Micro Hydro would never be required, a pipe diameter of one size smaller may be selected. Never select a pipe diameter of two sizes smaller as this may render the Micro Hydro virtually useless.

One size bigger in pipe diameter is often more effective than two pipes operating in tandem. A section of smaller diameter pipe can undo most of the benefit of the larger pipe before and after it, depending on the relative pipe sizes and how much of the smaller pipe is used.

Between 7 metres and 18 metres head 300 W is not achievable regardless of nozzle size and pipe size. Despite not being able to operate at close to maximum power the hydro would still be a valuable asset at these low heads.

Pipe sold in metric units is usually measured in outside diameter (OD) whereas pipe sold in imperial units is measured by inside diameter (ID).

Internal Diameter

Obviously it is the **inside** diameter (ID) of a pipe which affects its friction to the water. Pipe diameter measurement has been confusing because of conflicting conventions between ID and OD measurements and adopted standards for metric conversions. Unfortunately, the accepted standard for measuring 'metric' pipe is by OD whereas the 'imperial' convention has always been ID measurement. Some installations which have performed below expectations have resulted from this confusion. We recommend you actually measure the ID of the pipe to be used. Any fittings which the water must traverse will also have an effect on resultant pressure loss.

A factor often forgotten is that many plants and animals can cling to the walls inside the pipe. These make it thinner and rougher and can easily halve the output of the machine. To get an indication of this effect look at stones in the creek bed or ask neighbours, local poly-pipe suppliers, Department of Agriculture etc. If there is a crust on the rocks or there does seem to be a problem in your area then this must be allowed for and subtracted from the pipe radius.

Pipe friction is very counter-intuitive. The effect of diameter is fifth power, which means too small a pipe is much worse than you think. Also it means that a short section of thinner pipe or fittings with narrow ID will cost you more than you think in head.

Appendix B Performance Curves

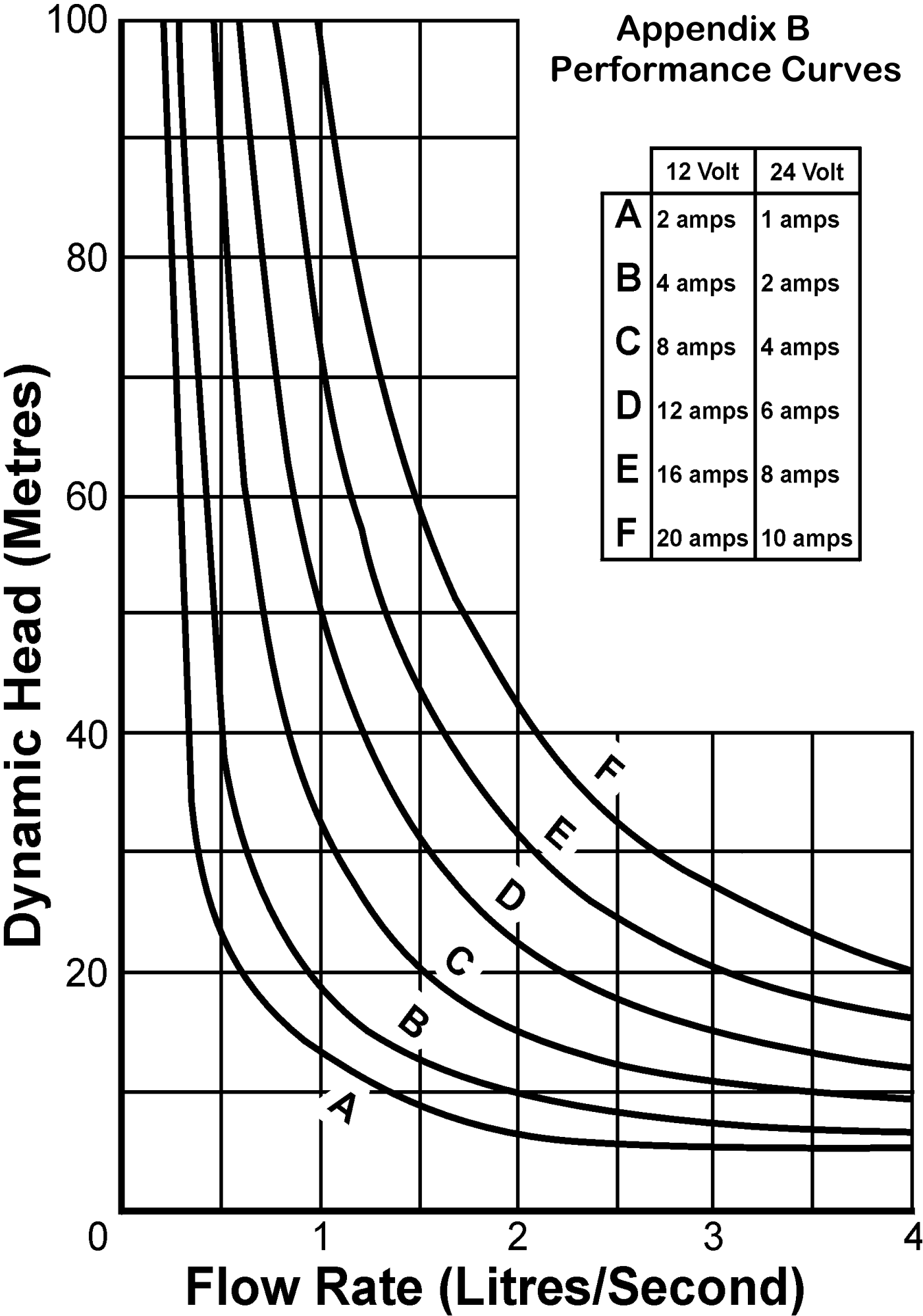

Appendix C Head Loss

metres per 100 metres

Nominal Pipe Diameter (OD for Metric and ID for Imperial) - Polyethylene Pipe – Type 50 – Class 6 ('B' class)														PVC	
l/sec	25mm	1"	32mm	1¼"	40mm	1½"	50mm	2"	63mm	2½"	75mm	3"	90mm	100mm	125mm
0.1	0.57	0.28	0.16	0.11	0.05	0.04	0.02	0.01	0.00	0.00	0.00	0.00	0.00	0.00	0.00
0.2	2.05	1.01	0.60	0.39	0.20	0.14	0.06	0.03	0.02	0.01	0.01	0.00	0.00	0.00	0.00
0.3	4.34	2.14	1.26	0.83	0.41	0.29	0.14	0.07	0.04	0.02	0.02	0.01	0.01	0.00	0.00
0.4	7.39	3.64	2.15	1.41	0.70	0.50	0.23	0.12	0.07	0.04	0.03	0.02	0.01	0.01	0.00
0.5	11.17	5.50	3.25	2.14	1.07	0.76	0.35	0.18	0.11	0.06	0.05	0.02	0.02	0.01	0.00
0.6	15.66	7.72	4.56	3.00	1.49	1.06	0.49	0.26	0.15	0.08	0.06	0.03	0.03	0.02	0.01
0.7	20.83	10.27	6.06	3.99	1.99	1.42	0.65	0.34	0.20	0.11	0.09	0.04	0.03	0.02	0.01
0.8	26.88	13.15	7.76	5.10	2.54	1.81	0.83	0.44	0.26	0.14	0.11	0.06	0.04	0.03	0.01
0.9	33.18	16.35	9.66	6.35	3.16	2.26	1.04	0.55	0.33	0.18	0.14	0.07	0.05	0.03	0.01
1.0	40.33	19.88	11.74	7.72	3.85	2.74	1.26	0.67	0.40	0.22	0.17	0.08	0.07	0.04	0.01
1.1	48.12	23.72	14.00	9.21	4.59	3.27	1.50	0.79	0.47	0.26	0.20	0.10	0.08	0.05	0.02
1.2	56.54	27.87	16.45	10.82	5.39	3.84	1.77	0.93	0.56	0.31	0.23	0.12	0.09	0.06	0.02
1.3	65.57	32.32	19.08	12.55	6.25	4.46	2.05	1.08	0.65	0.35	0.27	0.14	0.11	0.06	0.02
1.4	75.22	37.08	21.89	14.39	7.17	5.11	2.35	1.24	0.74	0.41	0.31	0.16	0.12	0.07	0.02
1.5	85.48	42.13	24.88	16.36	8.15	5.81	2.57	1.41	0.84	0.46	0.35	0.18	0.14	0.08	0.03
1.6	96.33	47.48	28.04	18.43	9.19	6.55	3.01	1.59	0.95	0.52	0.40	0.20	0.16	0.09	0.03
1.7		53.12	31.37	20.62	10.28	7.33	3.37	1.78	1.06	0.58	0.44	0.22	0.18	0.11	0.03
1.8		59.06	34.87	22.93	11.43	8.15	3.74	1.98	1.18	0.65	0.49	0.25	0.20	0.12	0.04
1.9		65.28	38.55	25.34	12.63	9.01	4.14	2.15	1.30	0.72	0.55	0.27	0.22	0.13	0.04
2.0		71.79	42.39	27.87	13.89	9.90	4.55	2.41	1.43	0.79	0.60	0.30	0.24	0.14	0.05
2.1		75.58	46.40	30.50	15.20	10.84	4.98	2.63	1.57	0.86	0.66	0.33	0.26	0.16	0.05
2.2		85.65	50.57	33.25	16.57	11.82	5.43	2.87	1.71	0.94	0.72	0.36	0.29	0.17	0.06
2.3		93.00	54.92	36.10	17.99	12.83	5.90	3.12	1.86	1.02	0.78	0.39	0.31	0.18	0.06
2.4			59.42	39.07	19.47	13.88	6.38	3.37	2.01	1.11	0.84	0.42	0.34	0.20	0.07
2.5			64.09	42.13	21.00	14.97	6.88	3.64	2.17	1.19	0.91	0.46	0.36	0.22	0.07
3.0			89.84	59.06	29.44	20.99	9.65	5.10	3.04	1.67	1.27	0.64	0.51	0.30	0.10
3.5				78.58	39.17	27.93	12.83	6.78	4.04	2.22	1.69	0.85	0.68	0.40	0.13
4.0					50.16	35.76	16.44	8.69	5.18	2.85	2.16	1.09	0.87	0.51	0.17
4.5					62.39	44.48	20.44	10.81	6.44	3.54	2.69	1.36	1.08	0.64	0.21
5.0					75.80	54.07	24.85	13.14	7.82	4.30	3.27	1.65	1.32	0.78	0.25
5.5					87.91	64.51	29.65	15.67	9.34	5.14	3.90	1.97	1.57	0.93	0.30
6.0						75.80	34.84	18.41	10.97	6.03	4.59	2.31	1.84	1.09	0.36
6.5						87.91	40.40	21.36	12.72	7.00	5.32	2.68	2.14	1.26	0.41
7.0							46.35	24.50	14.59	8.03	6.10	3.08	2.45	1.45	0.47
7.5							52.67	27.84	16.58	9.12	6.94	3.50	2.79	1.65	0.54
8.0							59.36	31.37	18.69	10.28	7.82	3.94	3.14	1.85	0.61
8.5							66.41	35.10	20.91	11.50	8.75	4.41	3.51	2.31	0.76
9.0							73.83	39.02	23.25	12.79	9.72	4.90	3.91	2.31	0.76
9.5							81.61	43.14	25.70	14.13	10.75	5.42	4.32	2.55	0.84
10.0							89.74	47.44	28.26	15.54	11.82	5.96	4.75	2.80	0.92
11.0								56.60	33.71	18.55	14.10	7.11	5.67	3.35	1.10
12.0								66.49	39.61	21.79	16.57	8.36	6.66	3.93	1.29
13.0								77.12	45.94	25.27	19.21	9.69	7.72	4.56	1.49
14.0								88.47	52.70	28.99	22.04	11.12	8.86	5.23	1.71

Appendix D

Pressure Conversion

metres	kPa	feet	PSI	metres	kPa	feet	PSI	metres	kPa	feet	PSI	metres	kPa	feet	PSI
5	49.03	16.42	7.11	10	98.1	32.84	14.22	20	196	65.7	28.4	45	441	147.8	64.0
5.1	45.96	16.75	7.25	10.2	100.0	33.50	14.51	20.5	201	67.3	29.2	46	451	151.1	65.4
5.2	46.86	17.08	7.40	10.4	102.0	34.15	14.79	21	206	69.0	29.9	47	461	154.4	66.8
5.3	47.76	17.41	7.54	10.6	104.0	34.81	15.08	21.5	211	70.6	30.6	48	471	157.6	68.3
5.4	48.66	17.73	7.68	10.8	105.9	35.47	15.36	22	216	72.3	31.3	49	481	160.9	69.7
5.5	49.56	18.06	7.82	11	107.9	36.12	15.65	22.5	221	73.9	32.0	50	490	164.2	71.1
5.6	50.46	18.39	7.96	11.2	109.8	36.78	15.93	23	226	75.5	32.7	51	500	167.5	72.5
5.7	51.37	18.72	8.11	11.4	111.8	37.44	16.21	23.5	230	77.2	33.4	52	510	170.8	74.0
5.8	52.27	19.05	8.25	11.6	113.8	38.10	16.50	24	235	78.8	34.1	53	520	174.1	75.4
5.9	53.17	19.38	8.39	11.8	115.7	38.75	16.78	24.5	240	80.5	34.8	54	530	177.3	76.8
6	54.07	19.70	8.53	12	117.7	39.41	17.07	25	245	82.1	35.6	55	539	180.6	78.2
6.1	54.97	20.03	8.68	12.2	119.6	40.07	17.35	25.5	250	83.7	36.3	56	549	183.9	79.6
6.2	55.87	20.36	8.82	12.4	121.6	40.72	17.64	26	255	85.4	37.0	57	559	187.2	81.1
6.3	56.77	20.69	8.96	12.6	123.6	41.38	17.92	26.5	260	87.0	37.7	58	569	190.5	82.5
6.4	57.67	21.02	9.10	12.8	125.5	42.04	18.21	27	265	88.7	38.4	59	579	193.8	83.9
6.5	58.57	21.35	9.24	13	127.5	42.69	18.49	27.5	270	90.3	39.1	60	588	197.0	85.3
6.6	59.48	21.67	9.39	13.2	129.5	43.35	18.77	28	275	92.0	39.8	61	598	200.3	86.8
6.7	60.38	22.00	9.53	13.4	131.4	44.01	19.06	28.5	279	93.6	40.5	62	608	203.6	88.2
6.8	61.28	22.33	9.67	13.6	133.4	44.66	19.34	29	284	95.2	41.2	63	618	206.9	89.6
6.9	62.18	22.66	9.81	13.8	135.3	45.32	19.63	29.5	289	96.9	42.0	64	628	210.2	91.0
7	63.08	22.99	9.96	14	137.3	45.98	19.91	30	294	98.5	42.7	65	637	213.5	92.4
7.1	63.98	23.32	10.10	14.2	139.3	46.63	20.20	30.5	299	100.2	43.4	66	647	216.7	93.9
7.2	64.88	23.65	10.24	14.4	141.2	47.29	20.48	31	304	101.8	44.1	67	657	220.0	95.3
7.3	65.78	23.97	10.38	14.6	143.2	47.95	20.77	31.5	309	103.4	44.8	68	667	223.3	96.7
7.4	66.68	24.30	10.53	14.8	145.1	48.60	21.05	32	314	105.1	45.5	69	677	226.6	98.1
7.5	67.59	24.63	10.67	15	147.1	49.26	21.33	32.5	319	106.7	46.2	70	686	229.9	99.6
7.6	68.49	24.96	10.81	15.2	149.1	49.92	21.62	33	324	108.4	46.9	71	696	233.2	101.0
7.7	69.39	25.29	10.95	15.4	151.0	50.57	21.90	33.5	329	110.0	47.6	72	706	236.5	102.4
7.8	70.29	25.62	11.09	15.6	153.0	51.23	22.19	34	333	111.7	48.4	73	716	239.7	103.8
7.9	71.19	25.94	11.24	15.8	154.9	51.89	22.47	34.5	338	113.3	49.1	74	726	243.0	105.3
8	72.09	26.27	11.38	16	156.9	52.55	22.76	35	343	114.9	49.8	75	736	246.3	106.7
8.1	72.99	26.60	11.52	16.2	158.9	53.20	23.04	35.5	348	116.6	50.5	76	745	249.6	108.1
8.2	73.89	26.93	11.66	16.4	160.8	53.86	23.33	36	353	118.2	51.2	77	755	252.9	109.5
8.3	74.80	27.26	11.81	16.6	162.8	54.52	23.61	36.5	358	119.9	51.9	78	765	256.2	110.9
8.4	75.70	27.59	11.95	16.8	164.8	55.17	23.89	37	363	121.5	52.6	79	775	259.4	112.4
8.5	76.60	27.91	12.09	17	166.7	55.83	24.18	37.5	368	123.2	53.3	80	785	262.7	113.8
8.6	77.50	28.24	12.23	17.2	168.7	56.49	24.46	38	373	124.8	54.0	81	794	266.0	115.2
8.7	78.40	28.57	12.37	17.4	170.6	57.14	24.75	38.5	378	126.4	54.8	82	804	269.3	116.6
8.8	79.30	28.90	12.52	17.6	172.6	57.80	25.03	39	382	128.1	55.5	83	814	272.6	118.1
8.9	80.20	29.23	12.66	17.8	174.6	58.46	25.32	39.5	387	129.7	56.2	84	824	275.9	119.5
9	81.10	29.56	12.80	18	176.5	59.11	25.60	40	392	131.4	56.9	85	834	279.1	120.9
9.1	82.00	29.89	12.94	18.2	178.5	59.77	25.89	40.5	397	133.0	57.6	86	843	282.4	122.3
9.2	82.91	30.21	13.09	18.4	180.4	60.43	26.17	41	402	134.6	58.3	87	853	285.7	123.7
9.3	83.81	30.54	13.23	18.6	182.4	61.08	26.45	41.5	407	136.3	59.0	88	863	289.0	125.2
9.4	84.71	30.87	13.37	18.8	184.4	61.74	26.74	42	412	137.9	59.7	89	873	292.3	126.6
9.5	85.61	31.20	13.51	19	186.3	62.40	27.02	42.5	417	139.6	60.4	90	883	295.6	128.0
9.6	86.51	31.53	13.65	19.2	188.3	63.05	27.31	43	422	141.2	61.2	92	902	302.1	130.9
9.7	87.41	31.86	13.80	19.4	190.3	63.71	27.59	43.5	427	142.9	61.9	94	922	308.7	133.7
9.8	88.31	32.18	13.94	19.6	192.2	64.37	27.88	44	431	144.5	62.6	96	941	315.3	136.5
9.9	89.21	32.51	14.08	19.8	194.2	65.02	28.16	44.5	436	146.1	63.3	98	961	321.8	139.4

Appendix E

Nozzle Combinations

Nozzle Diameters (mm)

Equivalent
Single Nozzle
Diameter

Nozzles	
1	2
18.1	18.1
18.1	15.6
18.1	12.8
18.1	11.1
15.6	12.8
15.6	11.1
18.1	Cap
12.8	11.1
15.6	Cap
12.8	7.8
11.1	9.0
11.1	7.8
12.8	Cap
11.1	4.5
11.1	3.2
11.1	Cap
9.0	4.5
9.0	3.2
9.0	2.3
9.0	Cap
7.8	3.2
7.8	2.3
7.8	Cap
6.4	3.2
6.4	2.3
6.4	Cap
4.5	3.2
4.5	2.3
4.5	Cap
3.2	2.3
3.2	1.6
3.2	Cap
2.3	1.6
2.3	Cap
1.6	Cap

Note: These figures relate to water use which will closely approximate the performance sequence. Where one nozzle is used the performance will be better than where two nozzles are used.

The nozzle combination to produce all of these options are as follows: 2 × 18.1mm, plus one of each of the following: 15.6mm, 12.8mm, 11.1mm, 9.0mm, 7.8mm, 6.4mm, 4.5mm, 3.2mm, 2.3mm, 1.6mm and a cap to close off one of the nozzle positions.

25.6
23.9
22.2
21.2
20.2
19.2
18.1
16.9
15.6
15.0
14.3
13.6
12.8
12.0
11.6
11.1
10.1
9.6
9.3
9.0
8.4
8.1
7.8
7.2
6.8
6.4
5.5
5.1
4.5
3.9
3.6
3.2
2.8
2.3
1.6

Appendix F Cable Sizing

Charging 12 Volt Battery

metres	Amps					
	2.5	5	7.5	10	15	20
5	1.8	1.8	1.8	1.8	2.9	2.9
10	1.8	1.8	2.9	2.9	4.6	7.9
15	1.8	2.9	4.6	4.6	7.9	13
20	1.8	2.9	4.6	7.9	13.6	13.6
25	1.8	4.6	7.9	7.9	13.6	21
30	2.9	4.6	7.9	13.6	13.6	21
40	2.9	7.9	13.6	13.6	21	32
50	4.6	7.9	13.6	21	21	32
60	4.6	13.6	13.6	21	32	49

Note:

- The body of the tables give cable sizes in mm².
- These tables are for determining appropriate cable sizes to give a maximum of 10% transmission loss (or voltage drop) on the DC side of the control box. To improve on performance use a larger cable size.
- For a 5% transmission loss double the cable sizes.
- Use 1.5mm² 3 phase cable for the AC transmission between the hydro unit and the control box.
- The control box is placed close to the battery bank in most circumstances.

Charging 24 Volt Battery

metres	Amps					
	1	2	4	6	8	10
10	1.8	1.8	1.8	1.8	1.8	1.8
20	1.8	1.8	1.8	1.8	2.9	2.9
30	1.8	1.8	1.8	2.9	4.6	4.6
40	1.8	1.8	2.9	4.6	4.6	7.9
50	1.8	1.8	2.9	4.6	7.9	7.9
60	1.8	1.8	4.6	7.9	7.9	13.6
70	1.8	2.9	4.6	7.9	7.9	13.6
80	1.8	2.9	4.6	7.9	13.6	13.6
100	1.8	2.9	7.9	13.6	13.6	21

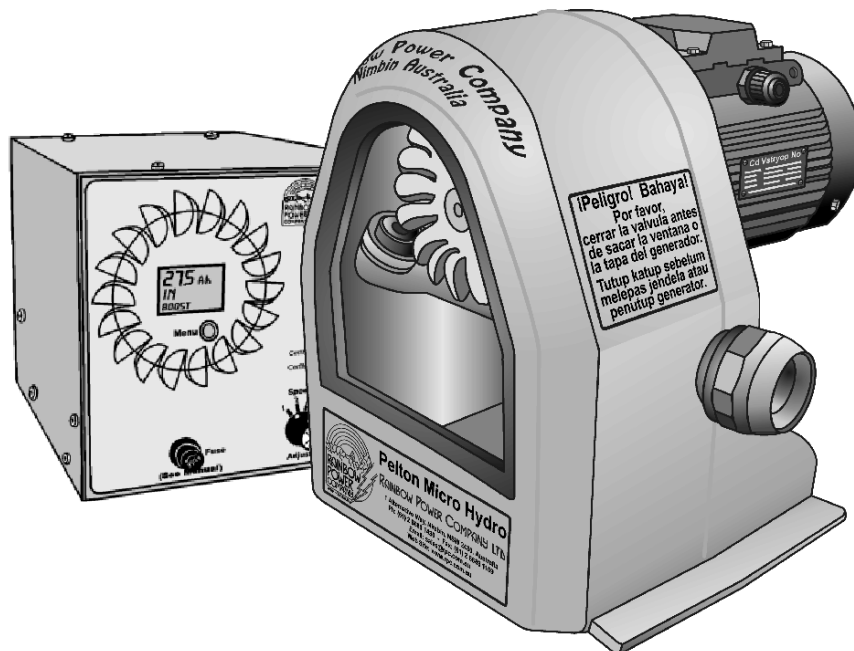
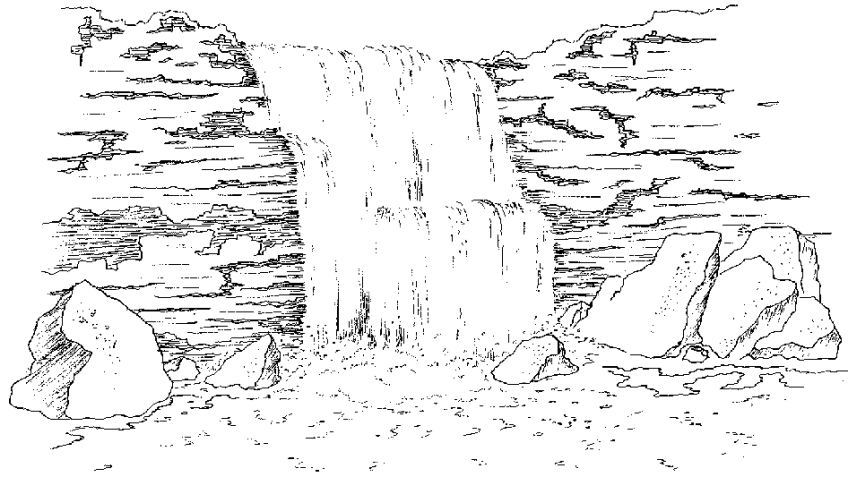

Appendix G

Additional Information for Electronic Technician

Concept

The electronics provide four important functions which have been condensed into the control box.

1. Excitation and speed control of the generator.

Induction generators require capacitors to supply the magnetising current and to tune out the winding reactance. The size of the capacitor effects speed, current and voltage of operation. Our circuit adds capacitors in four steps by adjusting the speed knob so as to match the speed of the generator to the best operating speed of the pelton wheel.

2. Load Dump. The Load dump is attached by a 240V cable with 3 conductors. One is green and yellow, one is brown and one is blue. The green and yellow wire must be connected to the exposed metal parts of the dump for safety. If the machine is run with the output disconnected then there is the risk of the generator voltage and temperature becoming excessive. Surplus energy from other power sources connected to the 12 or 24 volt circuit (eg solar panels) cannot be disposed of by the hydro Load Dump because the dump works in the high voltage circuit before the power is converted to 12 or 24 volt.

The voltage on the blue and brown wires can be as high as 370 volts DC, so correct installation and care is needed. It is tempting to connect the dump circuit to some low priority useful 240 volt load such as a water pump. This will not usually work as the dump is DC at varying voltages.

If the generator voltage reaches 370 volts peak the Load Dump circuit acts to stop it going any higher by passing current to the Load Dump element. If the battery is disconnected the total load must of course be diverted and the red light will come on.

To control over-voltage a transistor passes current to a resistor (750 watt immersion heater) sandwiched in an assembly of aluminium heat sinks. This reliably conducts the heat from the element and reduces the maximum temperatures reached to safe levels.

This load shedding function is also activated through an opto-coupler from the low voltage side of the circuit if the output voltage has reached the level preset on the regulator. The voltage being supplied to the resistor is DC varying from 0 to 370 volts according to the amount of power to be shed. There are no jumps or steps in its operation as the power fed to it has been chopped at 20 kHz with a varying mark/space ratio, and then filtered.

Many customers are offended by the "waste" of power in this energy dump resistor. There IS the possibility of using the power in a hot water heater, but elements over 1 kW may damage the control transistor. Also the element may burn out if there is a loss of water from the hot water tank. This may lead to the destruction of the Micro Hydro electronics, or the overcharging of the batteries.

A better way of using surplus power is to sequence loads on the battery side with low priority loads turning on as the batteries reach full charge. Items like water pumps, hot water heating, ceiling fans or refrigerators can all be allocated a priority. A problem with many loads is that they are either switched on or off (all or nothing) and may cycle on and off frequently unless the control system is sufficiently intelligent.

If there is water storage at the source it is sometimes worth considering a solenoid to turn off the water to the Micro Hydro when the battery reaches a preset level. Beware of the risk of water hammer when using a solenoid (refer to page 9). Here again there is risk of cycling if sufficient time delays are not built in.

3. Rectifier and control box. Although the power from the generator is 3 phase AC it is almost useless in this form. The voltage will vary from 100 to 300 and the frequency from 15 Hz to 100 Hz according to the setting on the control panel. Even if by chance the machine WAS running at 50 Hz 240 volt there would be little surge capacity past the continuous power the machine was running at and most practical loads would not be carried - the generator would simply de-excite.

To avoid the frequency problem we rectify the generator output first to high voltage DC, then convert it to 12 or 24 volt using a ferrite transformer running at 20 kHz. This approach is used so as to avoid the use of three heavy, inefficient, expensive, low frequency transformers which would also worsen the build-up characteristics of the generator. Driving into a bridge and converter the generator sees little load until it reaches 100 volts, so that little "over-speed" is necessary to make it excite.

This over-speed margin of typically 30% limits the minimum operating head as a situation can exist where charge would commence if sufficient speed could be attained to make the generator excite. With heads below 7 metres, or after the generator has been disassembled it may need a small pulse of current through the windings while it is stationary to reinstall residual magnetism. A torch battery is sufficient! Simply touch any two generator wires to the contacts of the battery for a second. This is called flashing, and is performed with other sorts of self excited generators also.

When the machine is used with long transmission wires with connections exposed to the weather this problem can be more common. The residual magnetism of the generator may only produce 1 volt, which may not pass dubious connections. If the 4 pin plug in the back of the control box is removed and a 12 volt battery applied across any two pins a small spark will indicate continuity and clean up any dubious contacts. This should make the machine build up when the plug is re-inserted.

The control box has variable voltage ratio, controlled by the trim knob so as to allow the generator to operate at the most efficient voltage. With too low a voltage there is predominant copper loss (and aluminium too in the rotor!) while too high a voltage means unnecessarily high flux levels and iron losses. The optimum can be approximated using only three taps on the transformer winding selected with the trim knob.

Fuse Protection

The function of the fuse is to protect the diodes in the control box in the event of reverse battery connection or from excess current. The wires to the battery will also be protected if the diodes in the control box fail, allowing current to flow in reverse. The diodes can fail if exposed to very high voltage on the battery line (32 volt in a 12 volt system), or more likely as a result of lightning surges.

Speed Knob

This knob brings into operation different excitation capacitors on positions 3, 2 and 1. The effect of this is to reduce the speed of the generator by 30% each step. The actual speed is dependent on power level, and to a lesser extent on the trim knob setting; but for the purpose of finding an optimum point of operation the interaction is unimportant.

The capacitors are added to different phases so as to provide some measure of symmetry, but symmetry is not very important for the performance of induction machines and the higher ripple produced in the output is still low enough to cause no observable problems. The switching of high voltage capacitors is very hard on switch contacts which tend to spot weld together. Coils have been installed in the current paths to limit the 'make' currents to tolerable levels. Even so, we do not recommend excessive operation of this control while the machine is running.

Electrical Subassemblies

The control box has no user serviceable parts inside and does contain dangerous voltages. As it only weighs 3.5 kg it is intended to be sent back to the manufacturer or qualified repairer in the event of damage or failure. If, however, a competent electronics technician wishes to attempt a repair, we will supply parts and technical assistance.

Spare Parts

Wherever possible we use common components that are readily available. Components that we make such as the coils, chokes and transformers are all available, and we feel it is very important to keep your system down-time as short as possible. There is no point spending great design effort on an efficient machine if it spends lengthy periods not operating.

Safety

Radio Frequency Interference (RFI)

Considerable effort has been taken to reduce RFI with snubbers, slow drive, filters and bypass capacitors, but still some noise gets out.

Earthing of the control box chassis will reduce this problem considerably. Earthing of your battery negative may also help. Schemes of earthing all to one point help a lot, particularly if there are long runs of transmission wire in your system.

The power from the generator is enough to kill. In the typically wet circumstances of a hydro installation a good contact is likely. In the interests of safety, the high voltage is totally isolated from the DC output in the same manner as a battery charger. It is also isolated from the case of the electronics, and from the case of the motor. Earthing arrangements are so left up to the consumer, and will depend on the installation. If power is being transmitted any distance at AC, then isolation of the high voltage circuits is not possible and the Multiple Earthed Neutral system should be adopted. The negative of the battery bank should also be earthed. As previously noted, this work must be done by a qualified electrician.

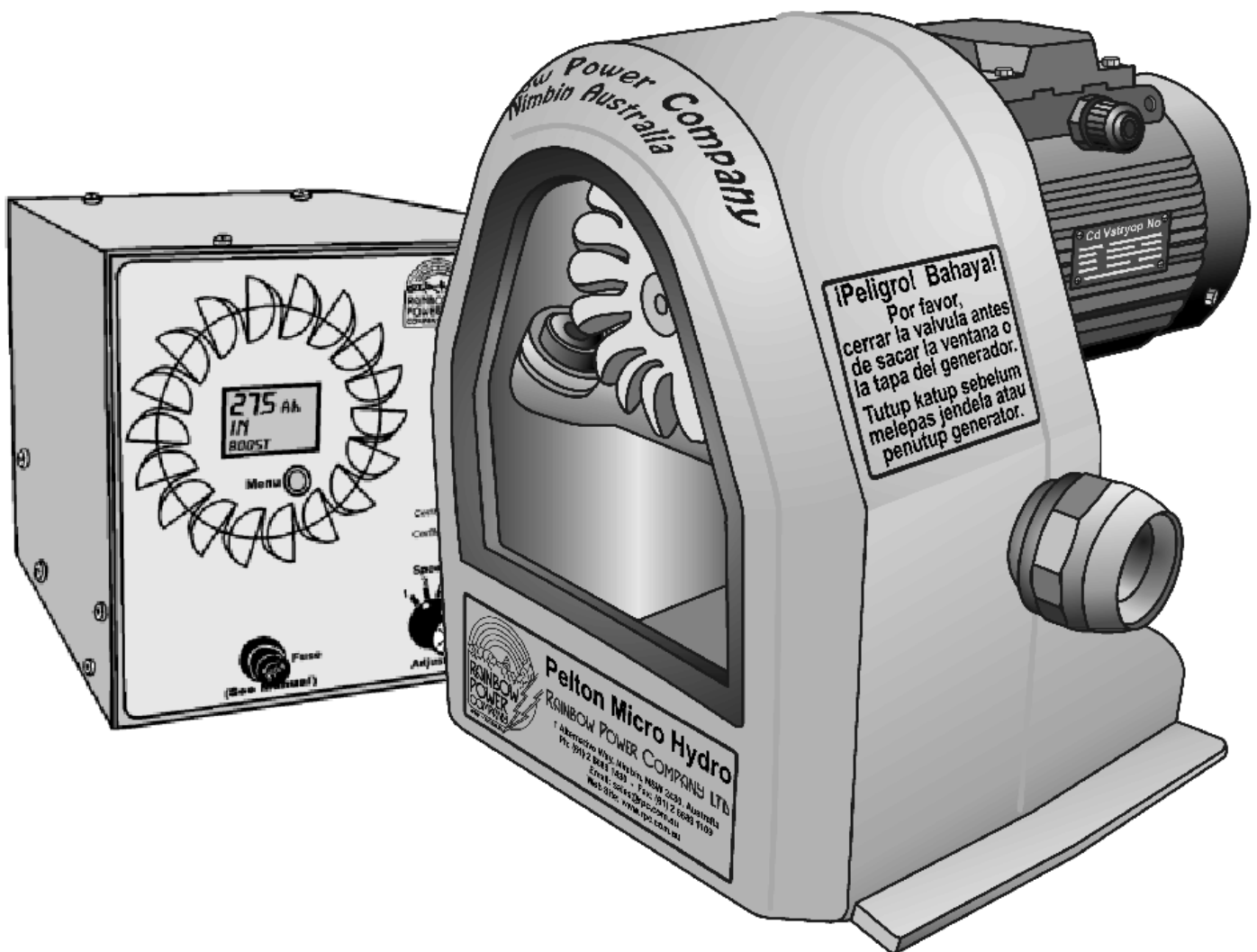

Appendix H

Environmental Impact

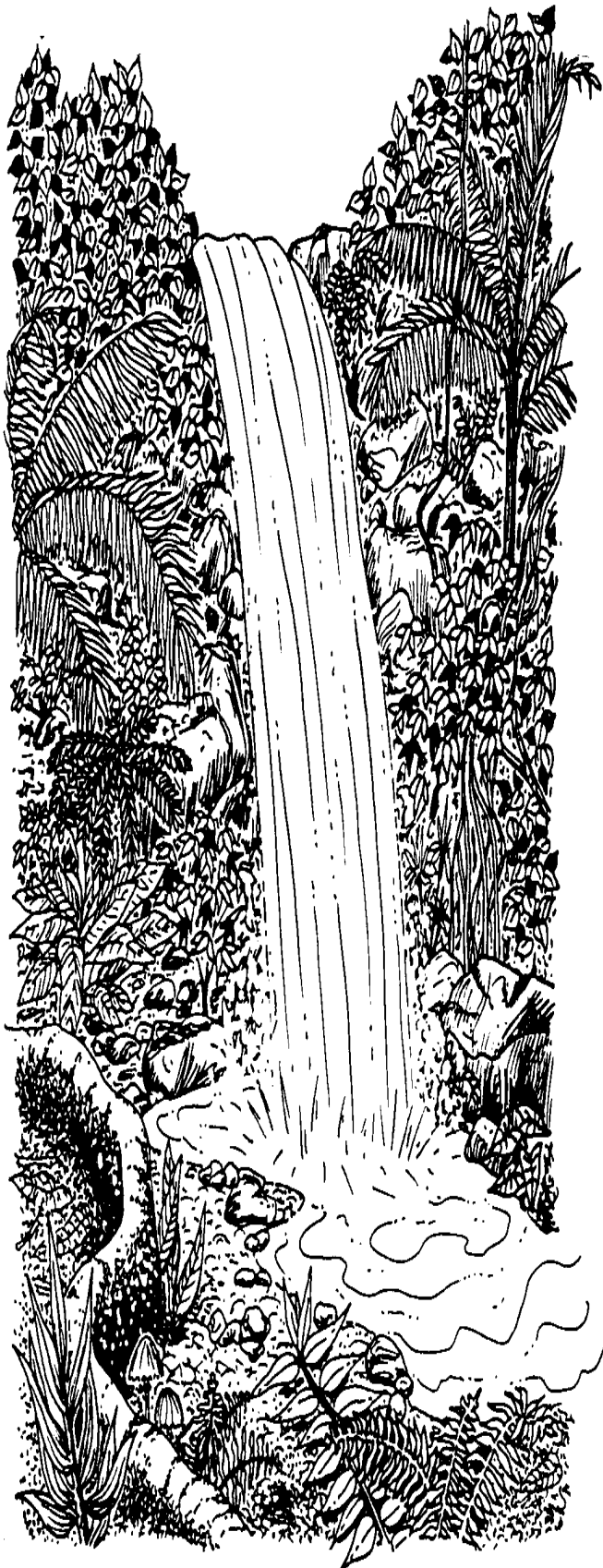

It became a fashionable rumour that so many of the "alternate" sources of energy required more energy to produce than they ever could repay in their life-span. This made them a sort of non-rechargeable battery rather than a generation system. This may have been the case with early solar panels, but things have come a long way since then. Our Micro Hydro stands up well to criticism. In a 10 year life span it would have produced the electricity otherwise requiring 15 tonnes of coal to be burned. Even this sells it short, because really the energy cost of the grid reticulation which we are comparing with should include lots for the transmission lines - their manufacture, erection and protection. The grid infrastructure level is indicated by the \$10,000+ connection cost that is typical, compared to the less than \$1,000 cost of polypipe and cable for a micro-hydro installation. The costing is of course complicated by the fact that the mains option supplies more of the house systems than does a small hydro system and that other environmental impacts are made necessary by it, such as a gas stove. At the end of the sums, Micro Hydros win easily. The more local environmental issues are often the deciding arguments. Many people find power lines very offensive because of cleared forest under the wires, 4WD tracks to cause soil erosion, and unsightly poles and wires across the view. Underground lines are usually too expensive and impractical in rough country.

A frequent concern is that the water used by the turbine is "wasted" and that the usual watercourse will be deprived by the flow through the penstock. Water flow in the creek is certainly reduced, but the effect is less than might be expected. During dry times the pipe stops as there is no point running the turbine at 1/10 litre per second. The only time there is a noticeable difference is when the creek is lowish. No animals will be high and dry and no plants affected as they rely on ground-water. Water continually joins a creek bed on the way down so the proportion of water used for power is small.

Tail water from a hydro system must be controlled properly, otherwise soil erosion, land slips and dead trees can result. Anything from pipes to old sheets of iron can easily solve this problem. Our Micro Hydro unit is made of a range of different material. The main power unit enclosure is made of recyclable low density polyethylene and the motor shell is made of cast aluminium. Its long term environmental impact is modest however as its life is indefinite and it is recyclable. The lifespan of the machine is usually limited by damage in transit or during floods. Please tie it to an immovable object if there is any chance of a flood covering the site. The biggest risk to a turbine is being washed away.