

Ulitium Lighting Kit

- 1 Overview
- 2 How does it work?
- 3 Planning the installation
- 4 Installing the Solar Panel
- 5 Connecting the Hub4
- 6 Installing the Ulitium
- 7 Operating the Ulitium
- 8 Troubleshooting
- 9 Energy Accounting
- 10 Energy Harvest
- 11 Energy Consumption
- 12 What next?

Instructions

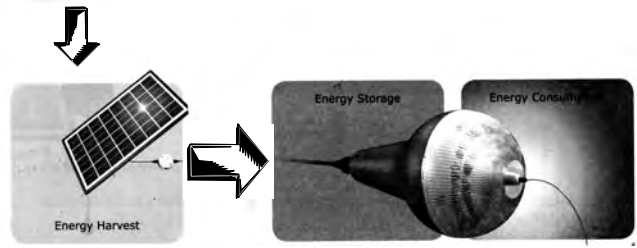

Overview

The Sundaya Ulitium Light kit system consists of very simple modular parts that you can connect together to form an expandable, energy-efficient lighting installation.

How does it work?

The concept of the basic Sundaya Lightkit is simple. During the daytime, energy is harvested from the sunlight using the Solar Panel, and converted into electricity. This electrical energy is then passed through the cables and Hub4 in your installation, to the Ulitium lamps.

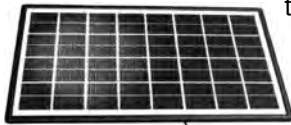

Solar panel with cable and bayonet plug

When not in use, the Ulitium lamp will store this electric energy, and then convert it back to light whenever it is switched on. It is considered an ELC (Electricity to Light Converter).



Hub4



Cable with bayonet plugs

You can have as many Solar Panels and Lights in your installation, as long as there is a good balance between energy harvested and energy consumed every day.

The harvesting capacity of the Solar Panel in every Sundaya Lightkit has been chosen to be in good balance for the number of energy consumers included in the kit. If you want to add more energy consumers (lamps, TV, laptop computer, etc.) please also consider installing additional Solar Panels to maintain this energy balance.

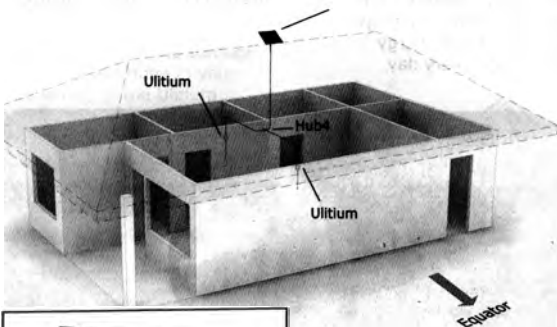

Planning the installation

Before you begin installing the system, please consider where you would like to suspend the lighting, and the Solar Panel's location on or near the roof.

The Solar Panel needs to face the equator, so choose the correct side of the roof.

The Solar Panel must not be overshadowed by trees or buildings throughout the day.



Judge the best placement and height for your Ulitium to get the light distribution you want for the room. See the chapter on how to switch on the Ulitium if you want to study beforehand its light distribution in the room.

Make sure the total distance from the Solar Panel to the Hub4 and the lights will not exceed the length of the cables. The Hub4 should be placed above the ceiling, at roughly equal distances to all the lights.

Installing the Solar Panel

The Solar Panel is designed to be mounted on a rigid pole. An aluminium or galvanized pipe of diameter 26 mm is ideal, but a thick PVC pipe is acceptable. The pole should be mounted on the rooftop, clamped or tied to the truss of the roof. If you cannot mount it there, you can also nail the pole on the outer wall of your house that is facing the equator, as long as the Solar Panel is not overshadowed.

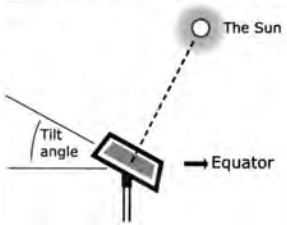

It is very important that the Solar Panel be positioned facing the equator. If necessary, also adjust the Solar Panel's tilt angle, so that at 12 o'clock the sun's rays should fall straight on the Solar Panel's top surface for an optimal sunlight energy harvest.



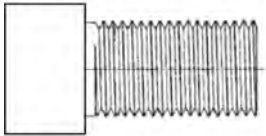

If replacing the original bolt, ensure that the bolt is not too long

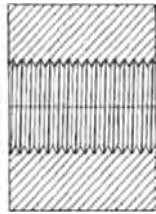

To adjust the angle of the solar panel, loosen the 4 "Allen" (socket head) screws with a suitable 3mm "Allen" key. Loosen each screw by approximately 2 turns and the angled swivel mount can be adjusted to the desired angle setting and re-tighten the 4 screws.

Caution: The screws will fall out if loosened about 5.5 turns. If any original screws are lost, they should be replaced with M4 x 8mm "Allen"-head (socket head) stainless screws. Screws longer than 8mm should not be used or damage to the solar panel may occur.

Connecting the Hub4

Under the roof, place the Hub4 somewhere between the future locations of the Ulitium lamps. Insert the Bayonet Plug of the cable from the Solar Panel, to one of the four ports on the Hub4. Twist the Bayonet Plug clockwise to lock it in place. (For 4 Light kits, connect one Hub4 to another using the extra cable with Bayonet Plugs).

OPTIONAL: for longer distances, you can also connect two Hub4's with an optional Sundaya DC cable, wired to the terminals underneath each Hub4.

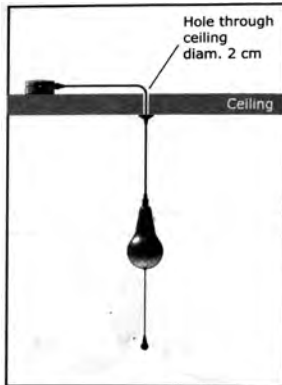
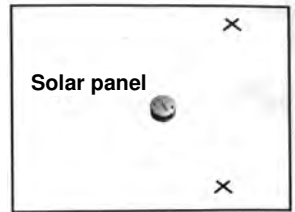

Installing the Ulitium

The Ulitium is designed to be suspended from the ceiling. At the precise location on the ceiling where you have planned to suspend the Ulitium, drill a hole 2 cm in diameter, barely large enough to allow a Bayonet Plug to pass through.

Insert the Bayonet Plug of the cable provided, into the port on top of the Ulitium. Pass other bayonet plug and rest of the cable through the hole in the ceiling you just made.

Slip the cable into the Ceiling Cap provided, through a slit on its side. Maintain the Ulitium at desired height. Then fasten Ceiling Cap to the ceiling with screws, covering up the hole on the ceiling.

Connect the bayonet plug that has been passed through the ceiling, to any available ports on the Hub4.

Repeat the above steps for all lamps in the kit*.

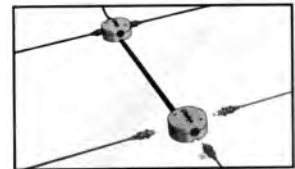

Operating the Ulitium

Observe the Cord Pull Switch hanging from the Ulitium. Inside the Switch there is a Spool for adjusting the Cord height.

There are 2 different modes of pulling the Switch: a brief tug and a sustained pull.

To turn ON the Ulitium, tug the Pull Switch briefly, and the lamp will gradually shine to full brightness. If the Switch is tugged again several times in succession, the brightness will dim in discrete steps from 100% to 50%, 10%, **OFF**, **ON** again, and so forth. But if you pull and hold the Switch momentarily, the lamp will grow dimmer in precise gradual steps. Release it when the desired level has been reached. If you pull and hold it again, the direction will be reversed, from dim to bright. For example: You dim gradually from 100% to, say 35%, release the Switch and then tug it briefly, the Ulitium will dim to 10%. Pull sharply again and the lamp turns off. If after dimming gradually to 35% in the example above, you pull and hold the Switch again, the lamp will gradually shine brighter towards 100%. During operation, the Ulitium will try to prolong usage by using an auto-dim feature. It will very slowly dim itself over time so that the lamp can stay switched on for a longer time, until the lamp eventually runs out of stored energy.

To disable the auto-dim feature, pull and hold the Switch in the direction from dim to bright. Release when the desired brightness has been reached.

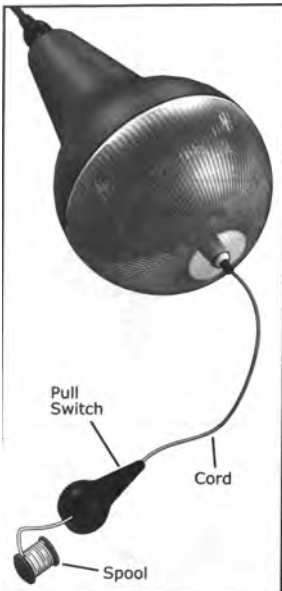

When the Ulitium is storing harvested electrical energy, the green indicator light behind the grated plastic lens will start to blink.

If the Ulitium does not have enough electrical energy in store, and you try to switch it on, the red indicator will blink 3 times, and then the Ulitium will turn off by itself. If you force the Ulitium to switch on again, it will only stay lit for 10 seconds. Do not force this condition. Give the Ulitium a chance to recharge as much as possible before using it again. Avoid wasting energy. Dim the lamp when you do not need full brightness, and turn it off when not needed. During the day, avoid using the Ulitium, and just let it store all the energy being harvested by the Solar Panel panels.

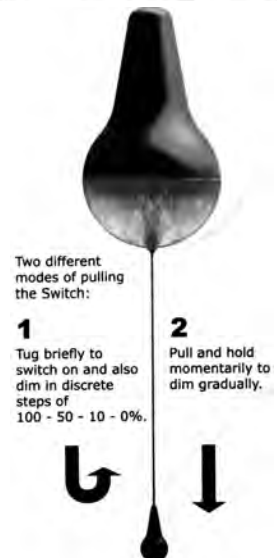

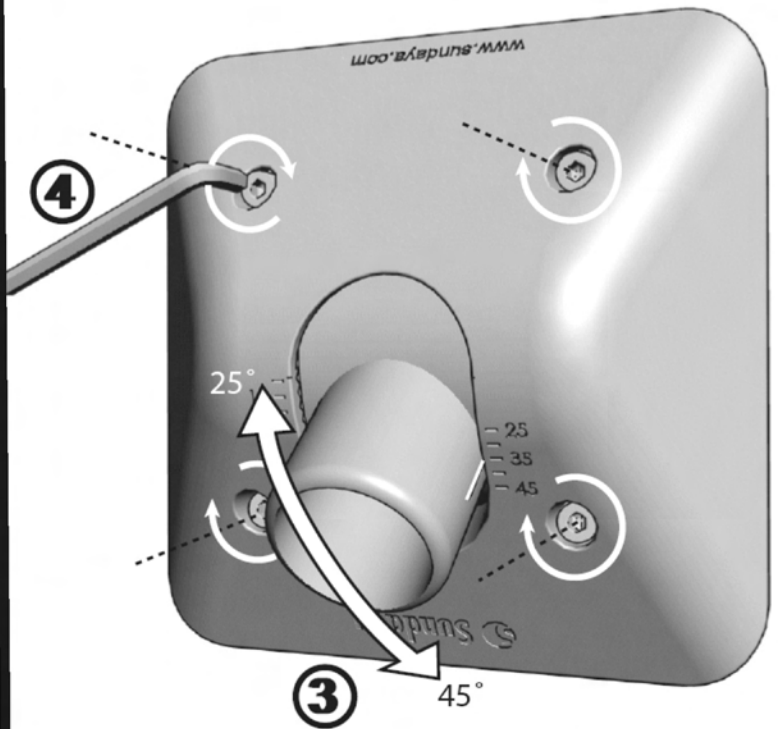
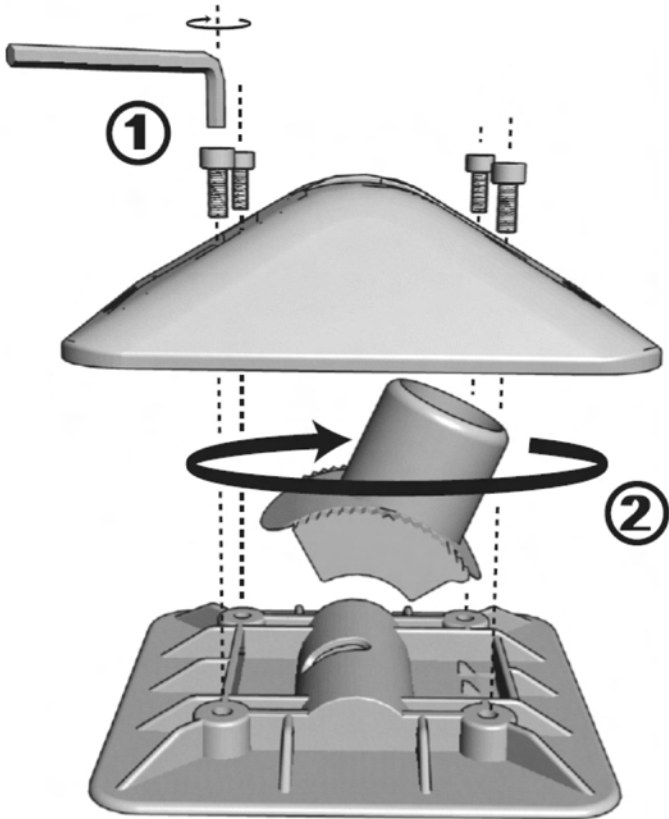
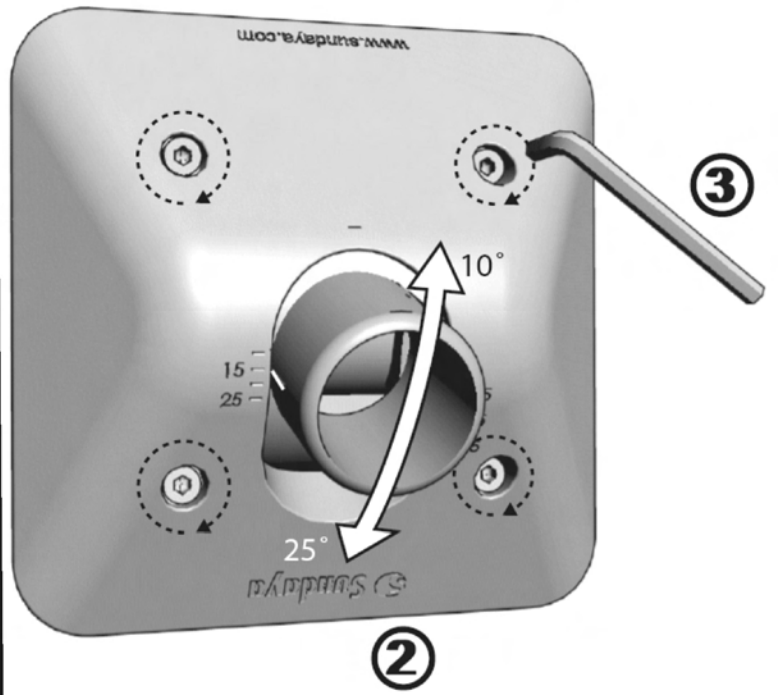
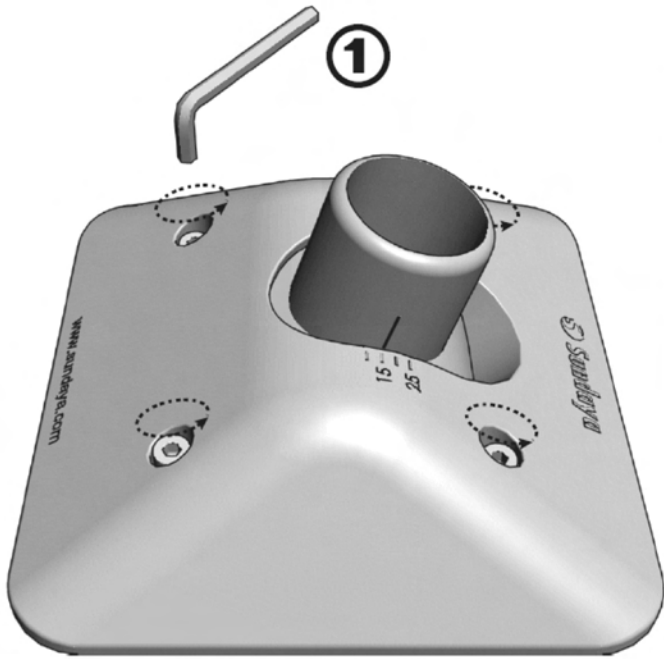
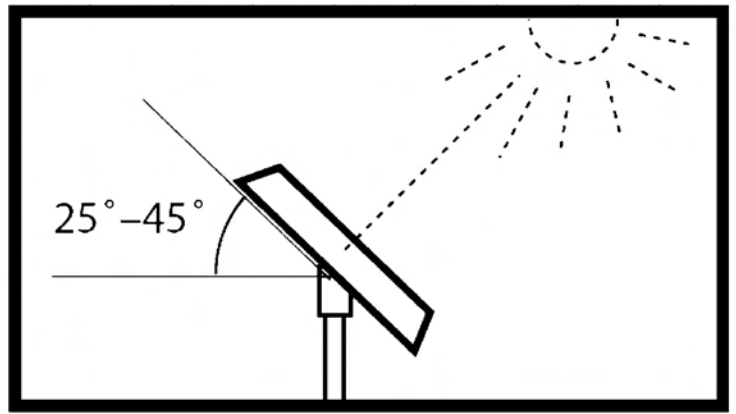
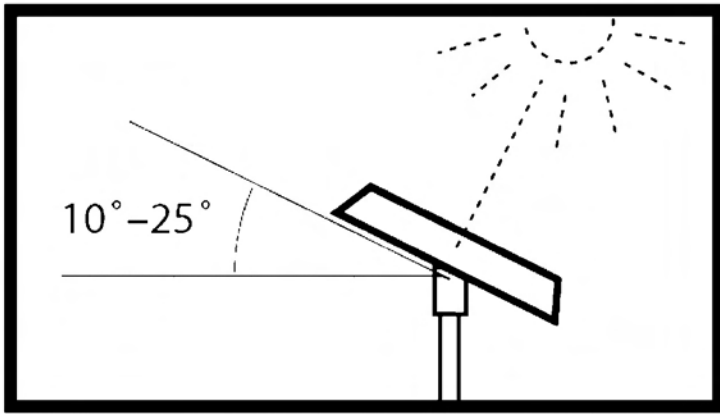

Troubleshooting

If for some reason, you tried switching on the Ulitium and it does not want to stay switched on, please follow these troubleshooting steps:

1. Ensure the Switch has been pulled in the correct manner.
2. If the Ulitium only stays on for a few seconds, it no longer has enough energy to operate. Allow it to recharge sufficiently during the day before using it again in the evening.

If during daylight the lamp should be recharging but the green indicator is not blinking:

1. Ensure the Solar Panel is facing in the right direction, and not overshadowed by trees or buildings.
2. Check the cabling from the Solar Panel all the way to the Ulitium, and verify all plugs are connected, to make sure the Ulitium has been getting energy from the Solar Panel during the day. Replace any damaged cable or plugs with original spare parts.
3. If still not recharging, bring the Ulitium along with the warranty card to the nearest Sundaya Service Centre.

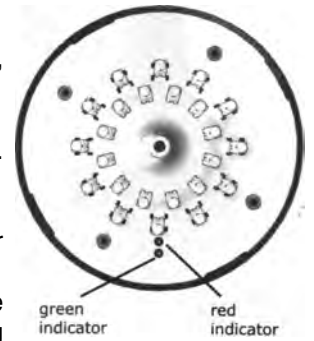

Energy Accounting

All Sundaya products are rated in Watt-hours for energy harvest, storage and consumption, and Lumens for light output of lamps.

Watt-hours is the unit to quantify energy (all forms of energy can be quantified in Watt-hours). The higher the Watt-hours number, the higher the energy amount. Lumen is the unit to quantify the total amount of light emitted by a lamp. The higher the Lumen number, the more light it emits.

Energy Harvest

The Sundaya solar panel range is named LEC (light to Electricity converter) followed by a number that indicates the amount of electrical energy (in Watt-hours) that it can harvest at 4.5 peak sun-hours per day (4.5 peak sun-hours is the average in tropical regions). 1 peak sun is the average peak solar light energy falling onto a flat surface inclined towards the sun on a sunny day. The nominal peak sun value is 1kW per square metre. Thus, if you total the solar energy for one day and the result is the same as 1kW for 4.5 hours, we say that on that day the total radiation equals 4.5 peak sun hours.

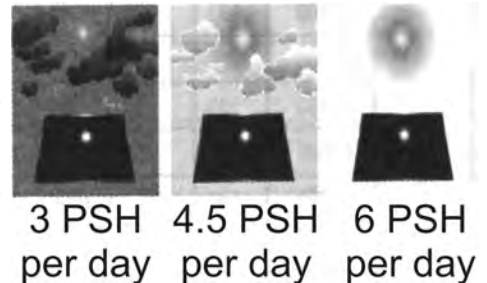

During bad weather or cloudy days the peak sun-hours can go as low as 1.5 peak sun-hours per day (psh/d), and in very bright days as high as 6 psh/d.

The table on page 18 of the manual supplied with the Sundaya Ulitium Kit gives the range of daily energy harvested from the available Solar Panel range.

Energy Consumption

Ulitium200 Light Output, Energy Consumption and Operating Hours.

* For a fully-charged Ulitium, at 100% brightness setting the operating hours can exceed 6 hours, because the Ulitium will gradually dim itself (Autodim) to allow an extra amount of operating hours.

** After the Ulitium switches off by itself because of a Low Voltage Disconnect, it should be recharged immediately. If left uncharged for more than 6 months, the battery pack may suffer damage, and no longer be rechargeable.

What next?

This product range is just the beginning of an exciting series of innovative products.

You can expand this basic installation with:

- other Lightkits,
- an STV with more lights, - a laptop computer,
- more Solar Panels,
- an AC to DC Converter to use along with grid electricity,
- more Ulitium,
- other accessories,
- or anything that will become available in this product range. The possibilities are unlimited.

Thank you and enjoy your Energy Independence!



RAINBOW POWER COMPANY LTD

A.B.N. 74 003 323 420

1 Alternative Way, Nimbin, NSW 2480, Australia
phone: (02) 6689 1430 fax: (02) 6689 1109
international: phone: +61 2 6689 1088 international: fax: +61 2 6689 1109
sales@rpc.com.au www.rpc.com.au