

Plasmatronics PL series (PL20, PL40, PL60) regulator settings

Regulator Program Function		Open Vented Wet Cell Lead Acid Battery					Sealed/Gel Lead Acid Battery		
Function	Description	Default 0	Trojan	Raylite	PV Stor	SunCycle	Default 1	SunGel	Sonnenschein
BMAX	Boost Voltage	15.0V	14.8V	14.7V	15.0V	15.0V	14.2V	14.7V	14.4V
EMAX	Equalise Voltage	16.0V	15.5V	15.6V	15.3V	16.5V	14.0V	15.0V	14.4V
ETIM	Equalise Time	1 hrs	2 hrs	2 hrs	0.5 hrs	2 hrs	0 hrs	2 hrs	2 hrs
EFRQ	Equalise Frequency	45 days		20 days	30 days	30 days	45 days	30 days	30 days
ABSV	Absorption Charge Voltage	14.0V		14.0V	15.0V	14.4V	14.0V	14.4V	14.1V
ATIM	Absorption Charge Time	2 hrs		4 hrs	0.5 hrs	3 hrs	2 hrs	3 hrs	3 hrs
FLTV	Float Voltage	13.8V	13.5V	13.5V	14.4V	13.8V	13.8V	13.8V	14.1V
BRTN	Boost Charge Trigger Voltage	12.3V		12.3V	13.2V	12.3V	12.3V	12.3V	12.3V
CHRG	Max. Charge Current		20% of C ₂₀		4% of C ₂₅	10% of C ₁₀	25% of C ₁₂₀	10% of C ₁₀	50% of C ₁₀₀
BFRQ	Boost Charge Frequency	15 days		1 day	1 day	1 day	15 days	1 day	1 day
TCMP	Temp. Comp. Table	0		1	0	1	0	2	1
ALRM	Low Level Alarm	11.4V			11.4V	11.4V	11.4V	11.4V	11.4V
LOFF	LVD cut-off	11.3V			10.8V	11.01V	11.3V	11.01V	10.5V
LON	LVD reconnect	12.8V				12.8V	12.8V	12.8V	12.8V
LDEL	LVD delay from LOFF	10 min				5 min	10 min	5 min	5 min
Make sure that PWM =1 (standard). PWM=2 or 3 when a shunt is connected to the load terminal.		All the above program settings will be in Program 4 (except for the two default settings which are either Program 0 or Program 1).							

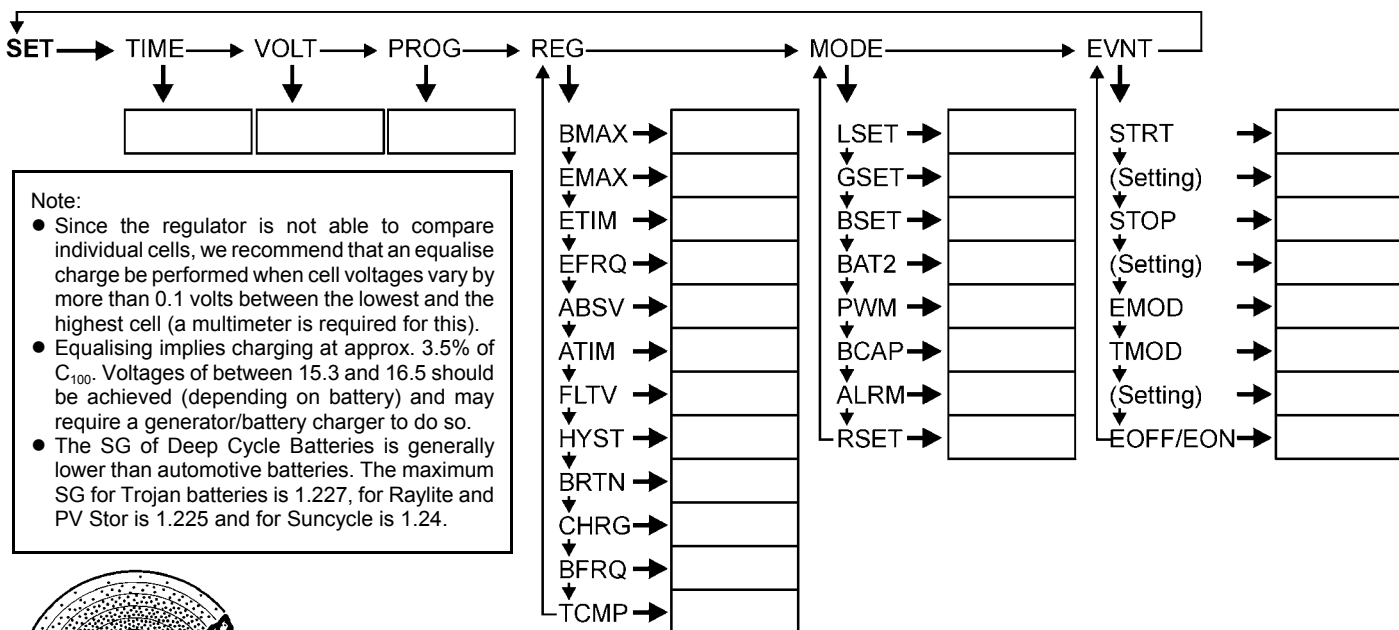

RAINBOW POWER COMPANY LTD

A.B.N. 74 003 323 420

1 Alternative Way, Nimbin, NSW, Australia 2480

phone: (02) 6689 1430

international: +61 2 6689 1088

fax: (02) 6689 1109

e-mail: info@rpc.com.au

web page: www.rpc.com.au